

SUNCAST®

Tools Needed For Installation

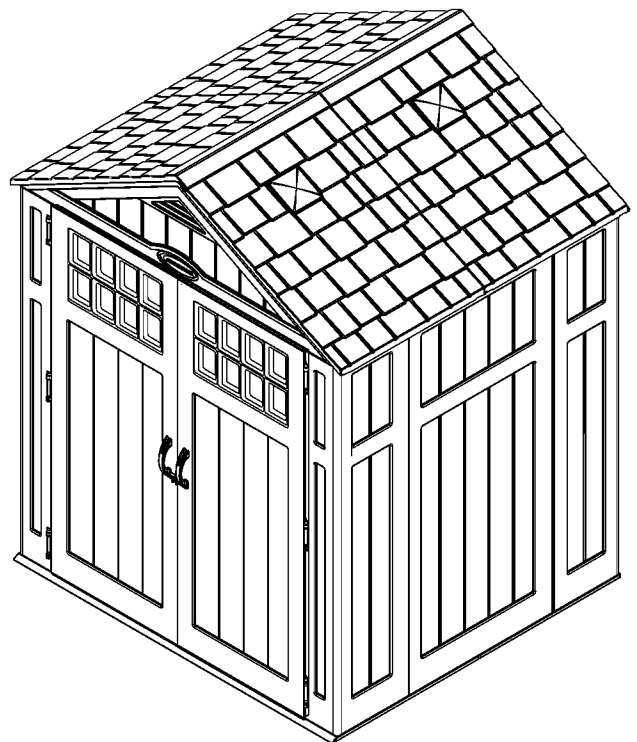

BMS6510 Blow Molded Shed Everett™ Storage Shed ASSEMBLY INSTRUCTIONS



Quality Control Number:



Before You Begin...

- **Consult your local authorities for any permits required to construct shed.**
Prior to the construction of your shed, check with the local building code official to review any required permits or building limitations.
- **A level and sturdy foundation is required before shed construction can begin.**
Review the site preparation information within the manual before beginning assembly.
- **Read instructions thoroughly prior to assembly.**
This kit contains parts that can be damaged if assembled incorrectly or in the wrong sequence.
- **Please follow instructions.**
Suncast is not responsible for replacing parts lost or damaged due to incorrect assembly.
- **Assistance is required during entire assembly.** 

IMPORTANT

OPEN ALL BOXES FIRST AND NEATLY LAYOUT PARTS. SMALL PARTS MAY BE CONTAINED IN EACH BOX. PLEASE REFERENCE THE PARTS LIST WITHIN THIS MANUAL TO VERIFY ALL PARTS ARE PRESENT.

COMPLETE SITE PREPARATION AND FOUNDATION CONSTRUCTION BEFORE UNPACKING ALL PARTS.



Caution

- Proper site preparation required.
- Shed not intended for use in extreme weather conditions.
- Shed not intended for storage of flammable or caustic chemicals.
- Store heavy items near the bottom of shed.
- Shed not intended for use by children.
- DO NOT stand, sit, or store items on storage shed roof.
- Treat carefully in extreme temperatures.
- Repair or replace broken parts immediately.
- Suncast is not responsible for damage caused by weather or misuse.
- At regular intervals inspect your shed to make sure that assembly integrity has been maintained.
- Periodically check that the location you have chosen to set your shed is still level.
- This kit contains parts with metal edges. Please be careful when handling.

Suncast Products and Replacement Parts



www.suncast.com
24 hours a day, 7 days a week, 365 days a year.



1-800-846-2345 or 1-630-879-2050



Shed Safety and Care

- Hot items, such as recently used grills, blowtorches, etc., must not be stored in the shed.
- Heavy articles should not be leaned against the walls, as this may cause panel distortion and permanent damage.
- Keep roof clean of snow and leaves.
- The shed walls and roof sections have a textured exterior, much like vinyl home siding. Over time, dust may accumulate in the texture. When combined with moisture, this could encourage the growth of moss or mold on the shed. To maintain the look of your shed, we recommend cleaning it each year with mild soap and water.
DO NOT use bleach, ammonia, or other caustic cleaners, and **DO NOT** use stiff bristle brushes. Failure to perform annual cleaning could result in permanent staining of the plastic. This is not a manufacturing defect and is not covered under warranty.

Assembly Day Tips

- Complete site preparation and foundation construction before unpacking parts and beginning assembly.
- **DO NOT** attempt to assemble on a day with strong winds.
- **DO NOT** attempt to assemble on days when temperature is below 32 degrees.
- Set aside appropriate amount of time to completely assemble shed. Assembly time is approximately 3 hours.
- Make sure you have assistance nearby to lift and secure parts in place.
- Wear light duty work gloves while assembling shed.
- Once roof is assembled, a flashlight may be of use when assembling smaller components inside shed.
- **DO NOT** use a torque wrench or hand drill to tighten provided Easy bolts. Use 010210410 Easy Bolt Easy Driver tool (provided) **ONLY**.
- Suncoast provides extra hardware for small fasteners for customer convenience. In some cases, there will be extra small fasteners once the assembly is complete.

Note: This product contains parts that are used in different orientations to construct the shed. Please take note of the orientation of the parts shown throughout this instruction manual. Failure to follow instructions could result in damage to parts. Suncoast is not responsible for replacing parts lost or damaged due to incorrect assembly.

IMPORTANT

OPEN ALL BOXES FIRST AND NEATLY LAYOUT PARTS. SMALL PARTS MAY BE CONTAINED IN EACH BOX. PLEASE REFERENCE THE PARTS LIST WITHIN THIS MANUAL TO VERIFYALL PARTS ARE PRESENT.

COMPLETE SITE PREPARATION AND FOUNDATION CONSTRUCTION BEFORE UNPACKING ALL PARTS.

Parts - BMS6510 Walls and Floor

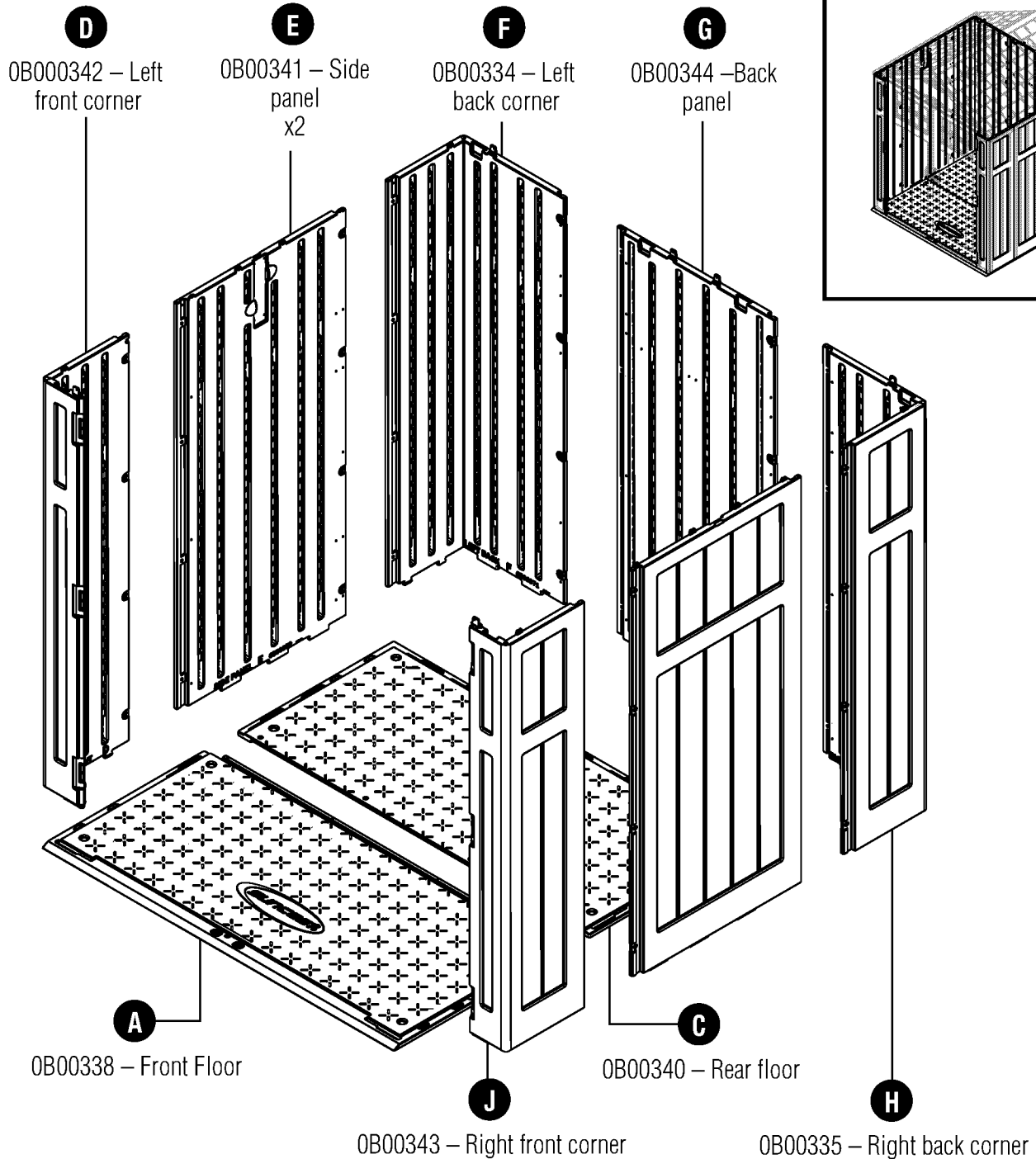

Parts - BMS6510 Doors

IMPORTANT

OPEN ALL BOXES FIRST AND NEATLY LAYOUT PARTS. SMALL PARTS MAY BE CONTAINED IN EACH BOX. PLEASE REFERENCE THE PARTS LIST WITHIN THIS MANUAL TO VERIFY ALL PARTS ARE PRESENT.

COMPLETE SITE PREPARATION AND FOUNDATION CONSTRUCTION BEFORE UNPACKING ALL PARTS.

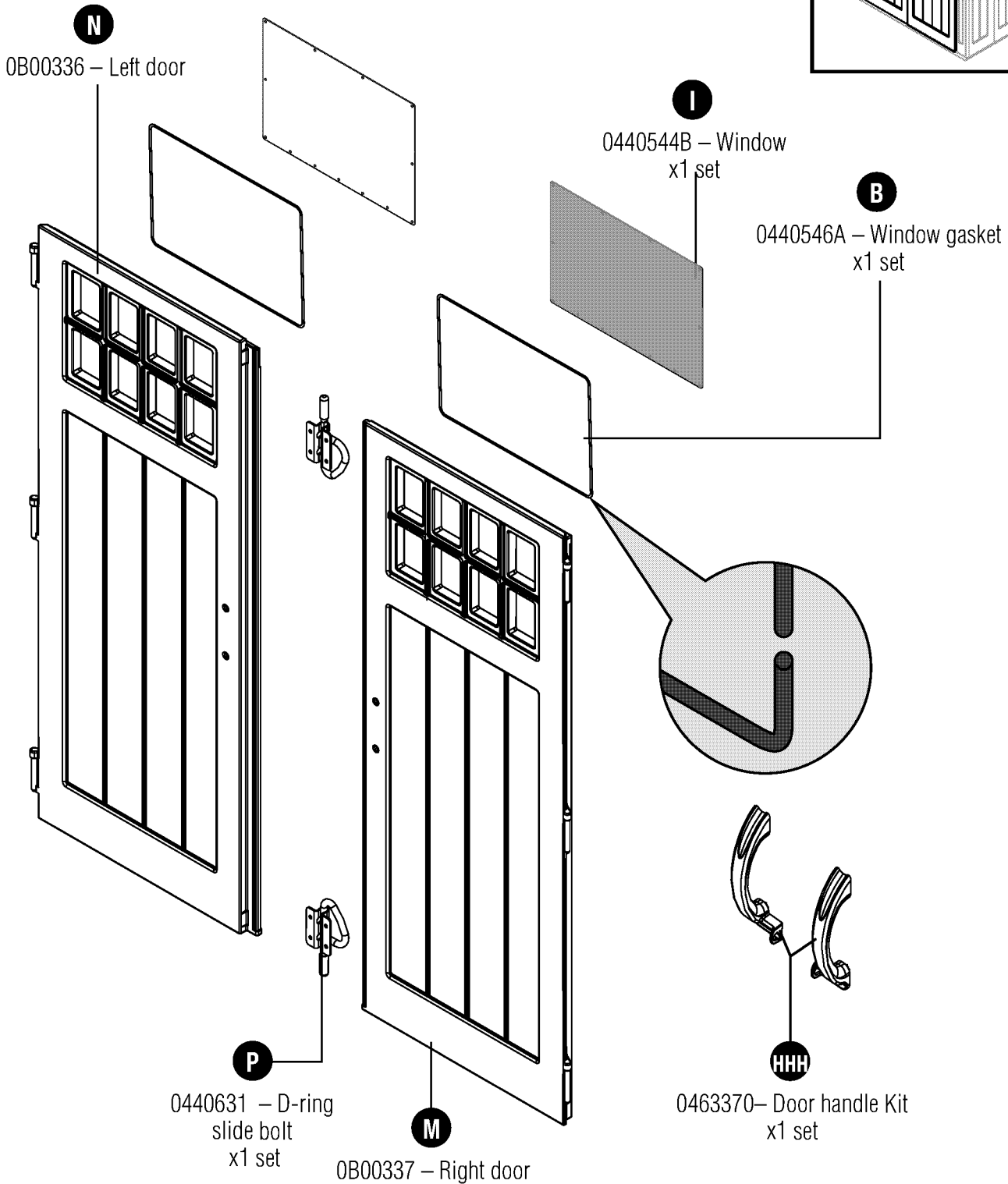
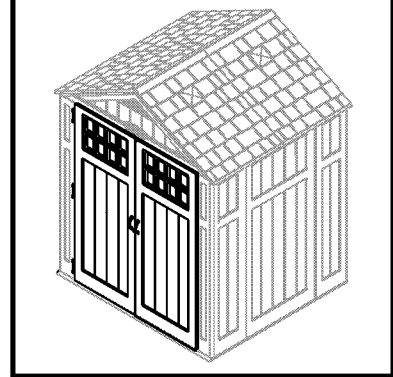

Parts - BMS6510 Header

IMPORTANT

OPEN ALL BOXES FIRST AND NEATLY LAYOUT PARTS. SMALL PARTS MAY BE CONTAINED IN EACH BOX. PLEASE REFERENCE THE PARTS LIST WITHIN THIS MANUAL TO VERIFY ALL PARTS ARE PRESENT.

COMPLETE SITE PREPARATION AND FOUNDATION CONSTRUCTION BEFORE UNPACKING ALL PARTS.

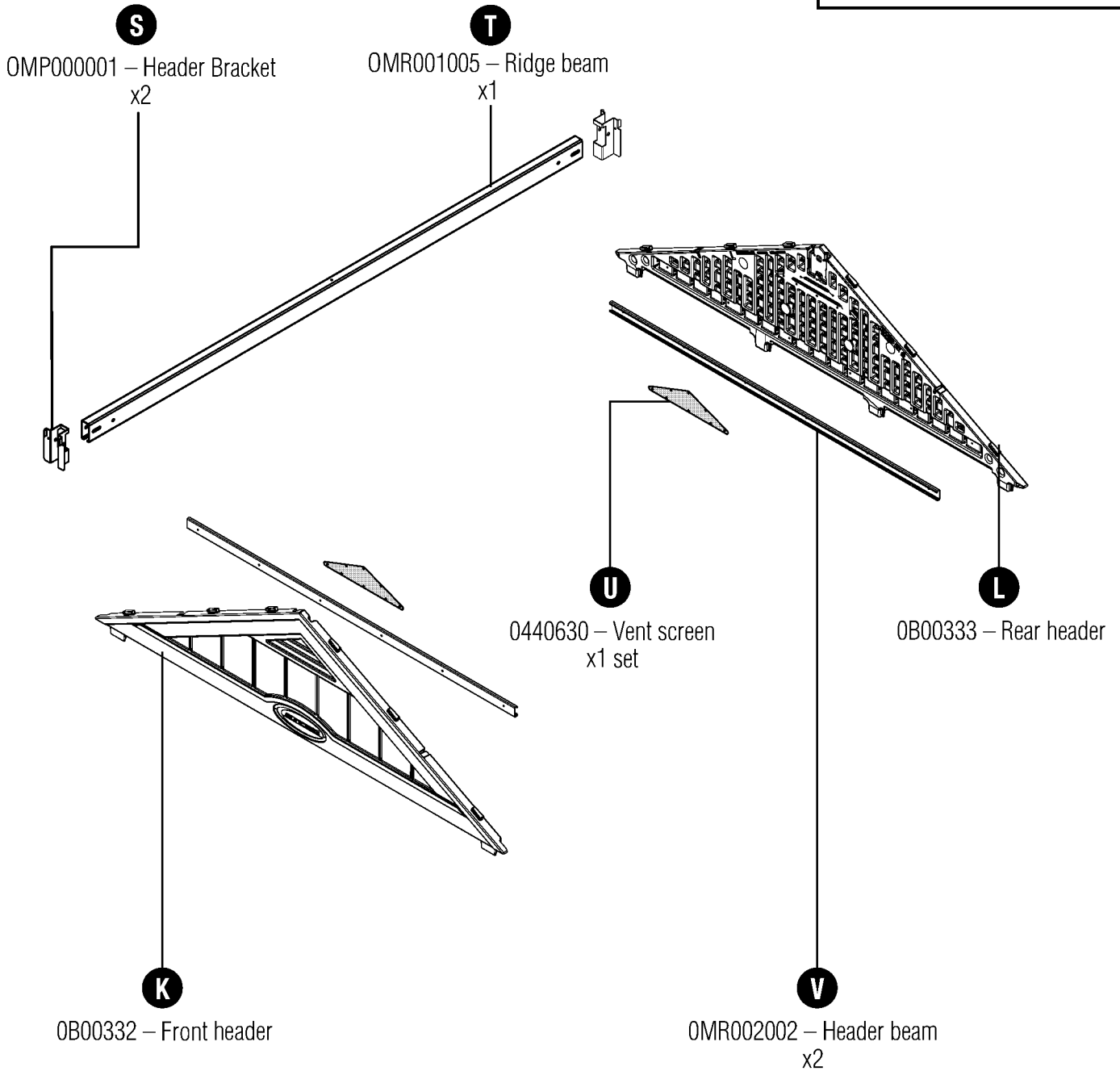
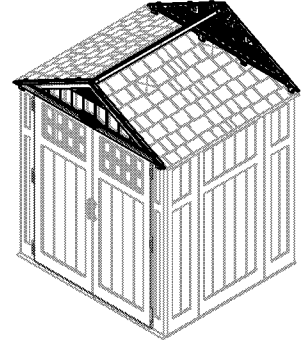

Parts - BMS6510 Roof

IMPORTANT

OPEN ALL BOXES FIRST AND NEATLY LAYOUT PARTS. SMALL PARTS MAY BE CONTAINED IN EACH BOX. PLEASE REFERENCE THE PARTS LIST WITHIN THIS MANUAL TO VERIFY ALL PARTS ARE PRESENT.

COMPLETE SITE PREPARATION AND FOUNDATION CONSTRUCTION BEFORE UNPACKING ALL PARTS.

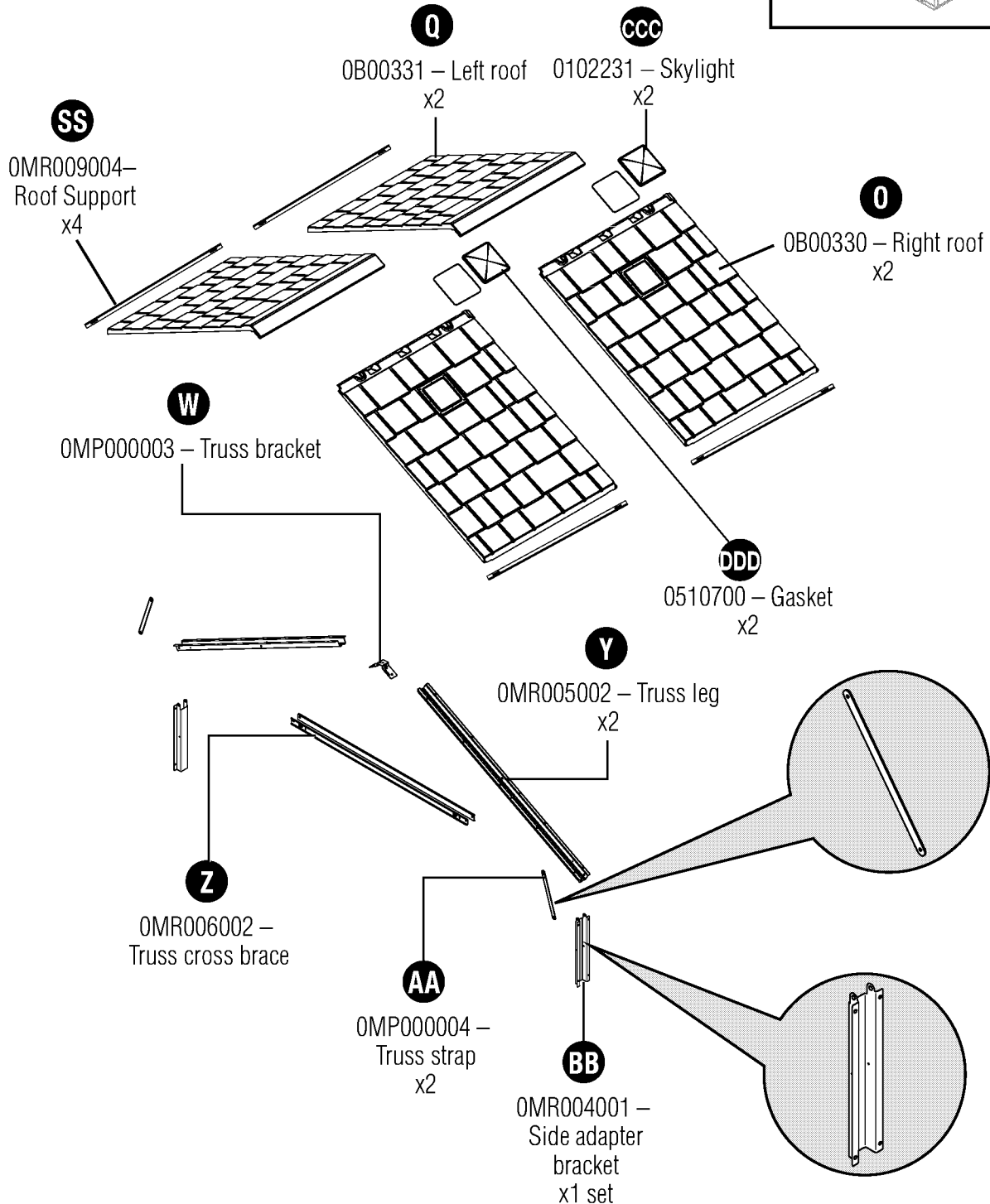
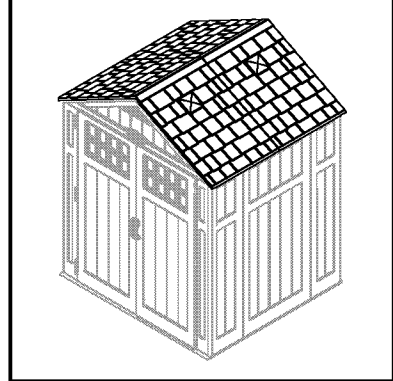

Hardware - BMS6510

OMP000002 – Hardware bag

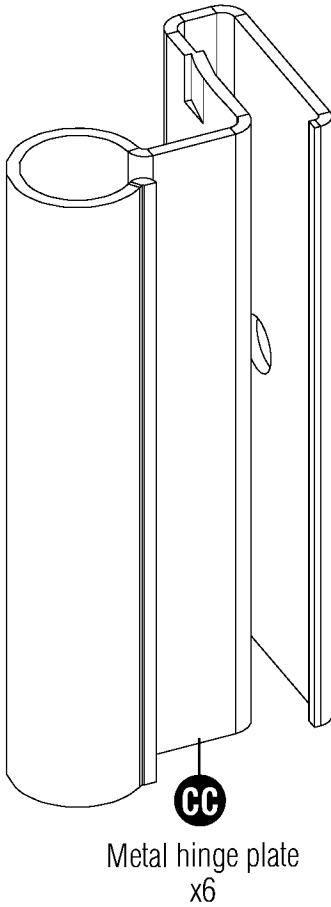

0480340 – Hardware bag

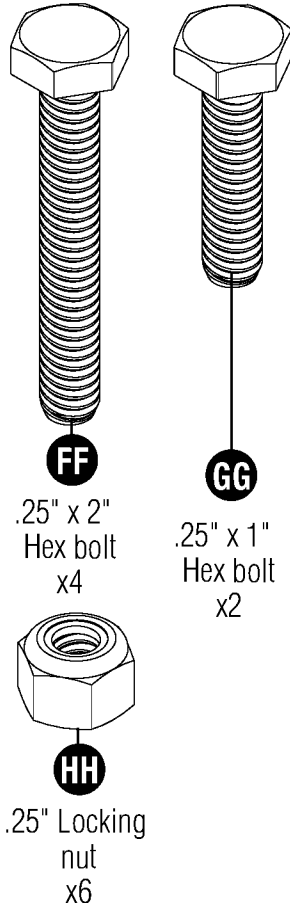

0480342 – Hardware bag

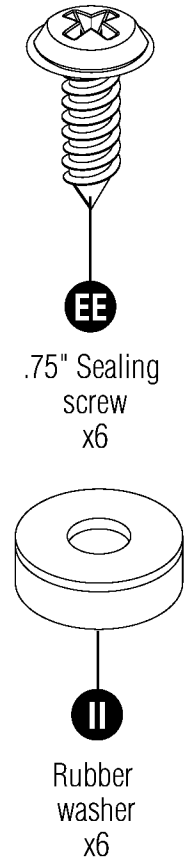

0480217 – Hardware bag

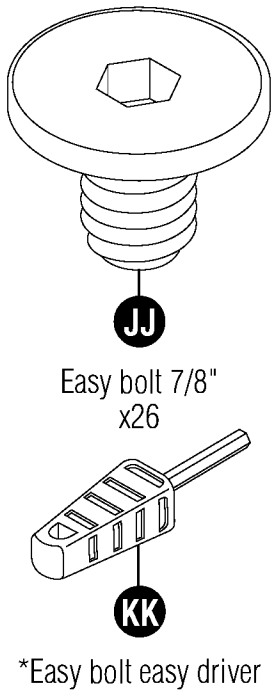

0480298A and 0480336 – Hardware bag

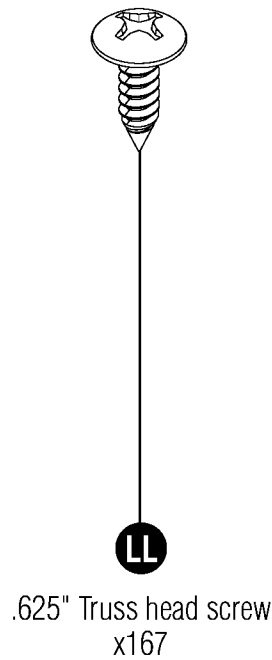

0480337 – Hardware bag

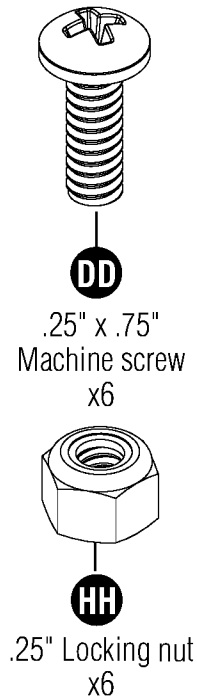

0480374 – Hardware bag

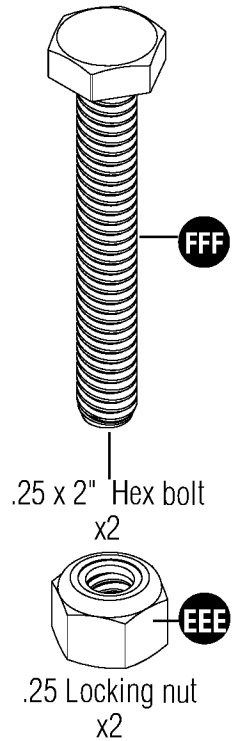

Hardware shown at actual size (*Unless otherwise noted.) Extra hardware provided. Not all are used.

Door Handle Kit - BMS6510

0463370

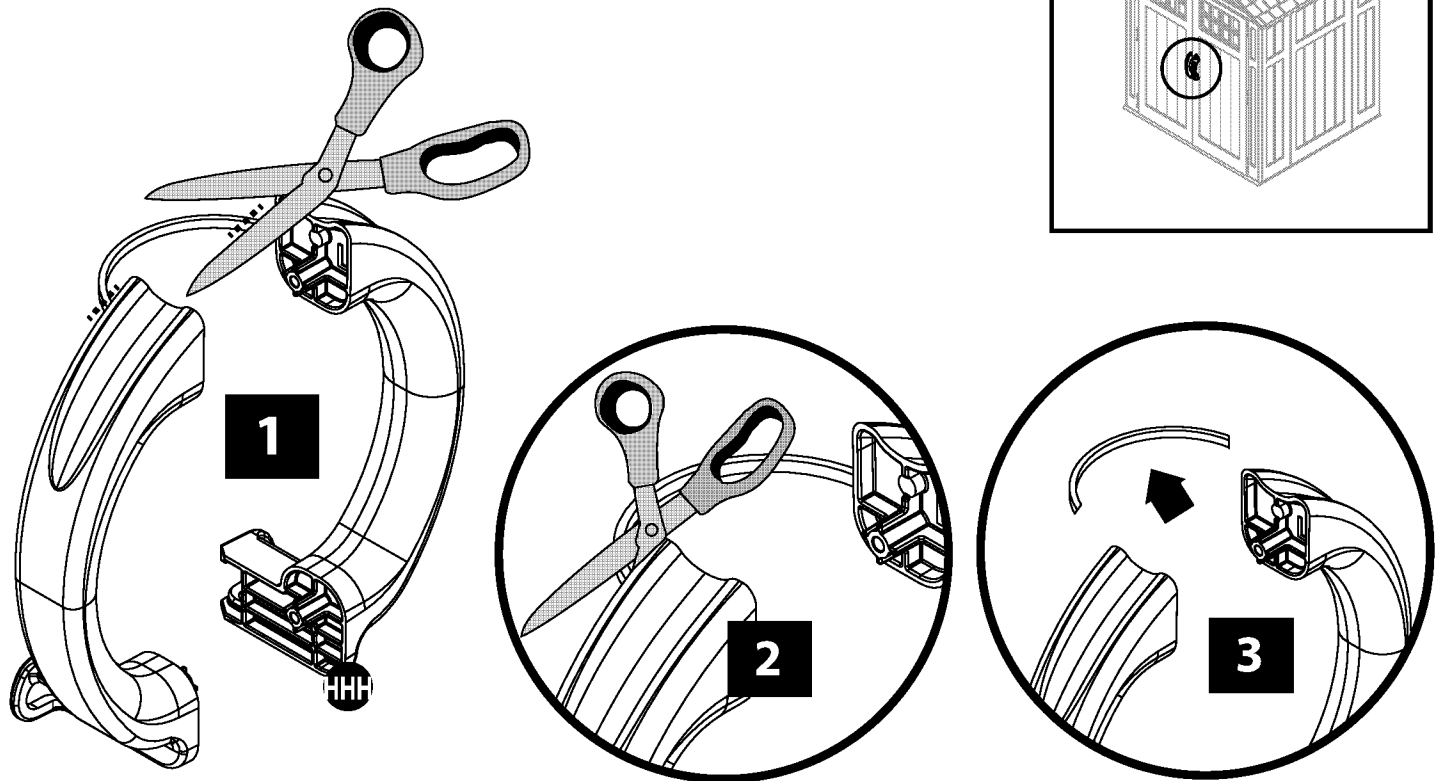
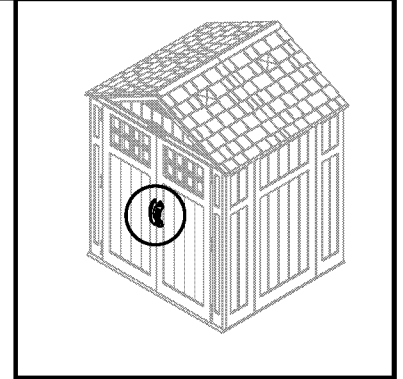

Hardware

0480370

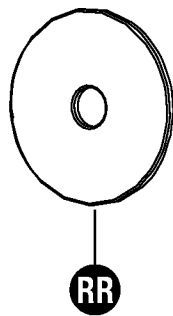

.25" Washer
x4

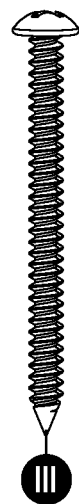

.25" x 1" Pan head screw
x4

Hardware shown at actual size (*Unless otherwise noted.) Extra hardware provided. Not all are used.

Site Preparation and Platform Construction

Materials **NOT** supplied with BMS6510 Shed Kit

Note: Site preparation is required for this shed. Placing the shed on a constructed foundation is required. Without a constructed foundation, settling will probably occur, causing distortion and damage to the shed. Suncast is not responsible for replacing parts damaged or property lost due to incorrect assembly. Warranty requires foundation.

Note: Complete the site preparation and foundation construction before unpacking parts and beginning assembly. For tips on site preparation, go to www.suncast.com, consult retailer, or local code.

To prepare your shed site, follow the steps below:

- 1) Consult your local authorities for building codes and covenants before beginning foundation or erecting shed.
- 2) Before any digging, check with local utilities to determine location of buried cables, pipes, etc.
- 3) Decide which type of foundation you want:
 - Concrete slab, 4" thick

OR

- Wood platform

Use exterior grade wood. The wood platform should be set on pier blocks or footing. Consult your local retailer for help to determine the best anchoring method for your particular installation. The provided plans are sized for the minimum number of cuts to lumber and plywood.

- 4) Prepare the building site:
 - The ground should slope away from the foundation area to provide drainage.
 - The foundation surface must be flat and level.
 - A vapor barrier should be provided to prevent excessive condensation in the shed.
 - Follow local building codes for a proper vapor barrier.
- 5) Anchoring the shed to the foundation:
 - Consult your local retailer for help to determine the best anchoring method for your particular installation.
 - To secure the shed to a concrete slab, use masonry fasteners available at your local hardware retailer.
 - To secure the shed to a wood platform, use 1/4" x 3" long lag screws with washers.

Anchoring floor panel to concrete slab

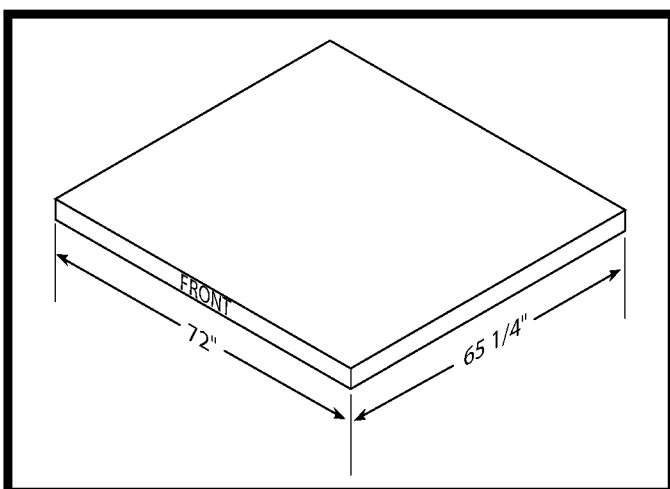

- Secure shed to concrete slab using masonry fasteners.
- Dimensions allow for shed to fit within the nearest 1" on each side.

Anchoring floor panel to wood platform

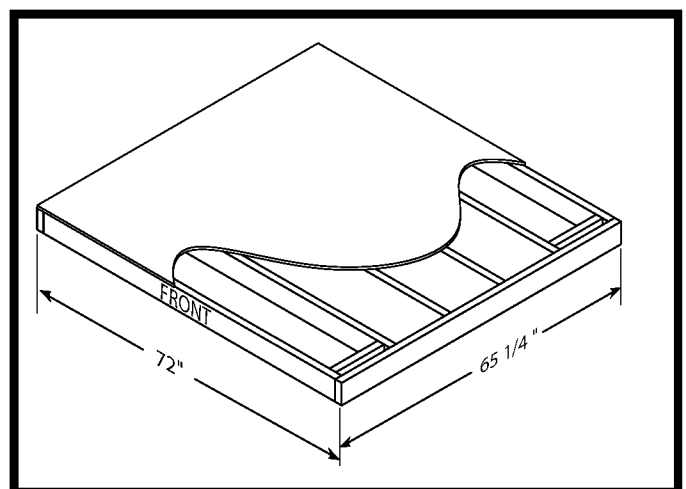

- Secure shed to wood platform using 1/4" x 3" lag screws.

Site Preparation and Platform Construction (continued)

Materials **NOT** supplied with BMS6510 Shed Kit

Wood platform critical spacing

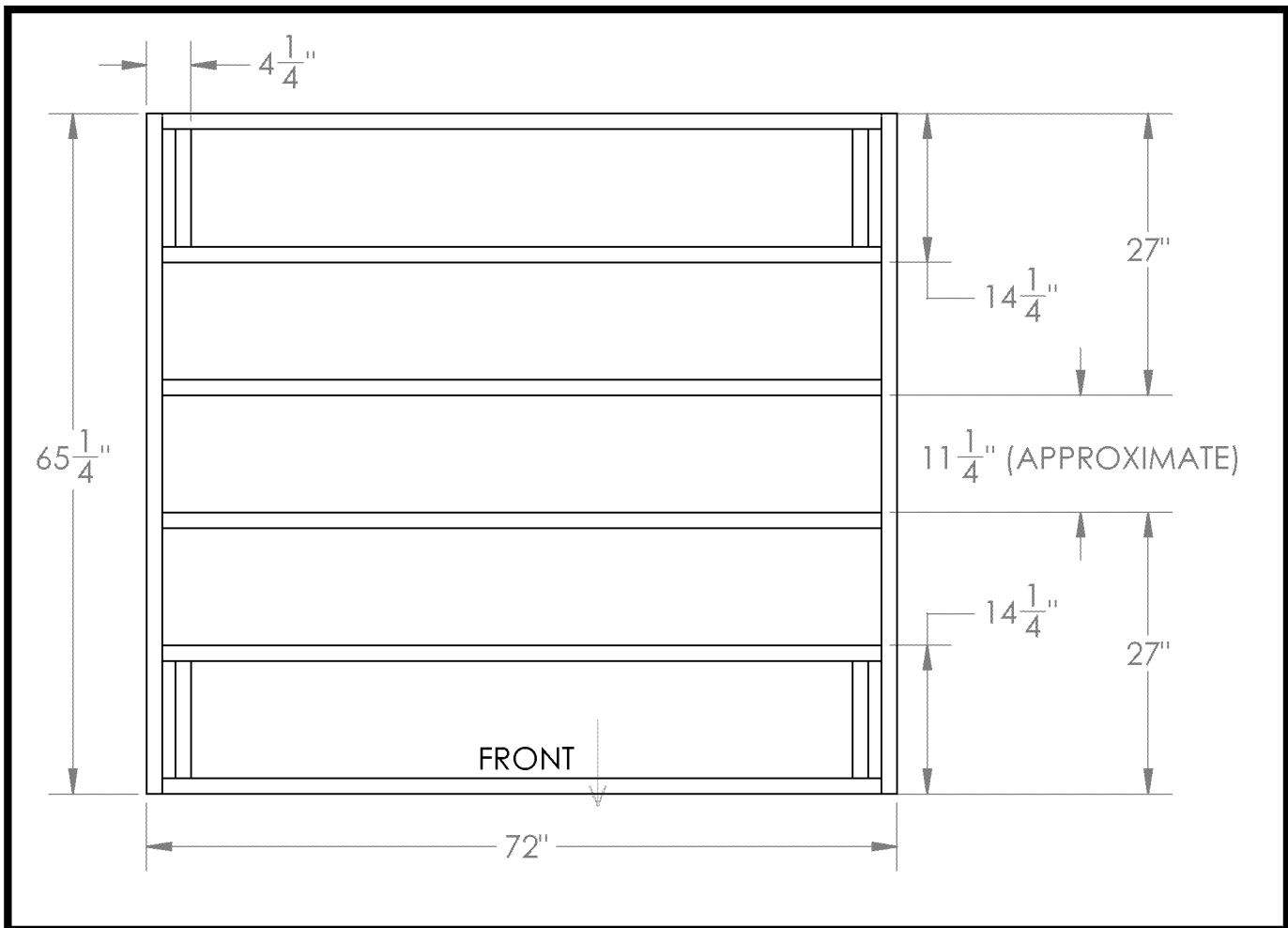

- Check all critical spacing measurements.

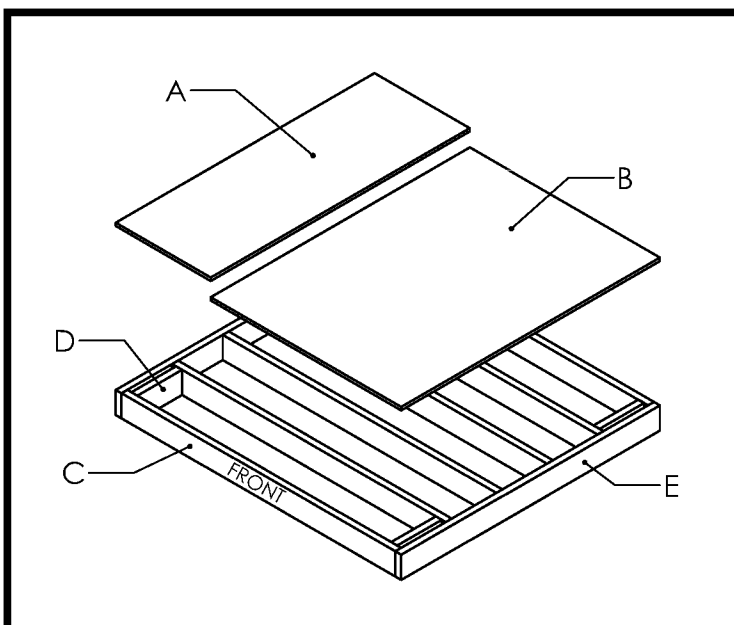

Materials list

Item	Qty	Size
A	1	24" x 65 1/4" x 3/4"
B	1	48" x 65 1/4" x 3/4"
C	6	2" x 6" x 69"
D	4	2" x 6" x 11 1/4"
E	2	2" x 6" x 65 1/4"

PLEASE NOTE-DIMENSIONAL LUMBER IS ACTUALLY 1/2" SMALLER THAN NOTED SIZES (A 2x6 BOARD ACTUALLY MEASURES 1 1/2" X 5 1/2")

Door Pre-Assembly

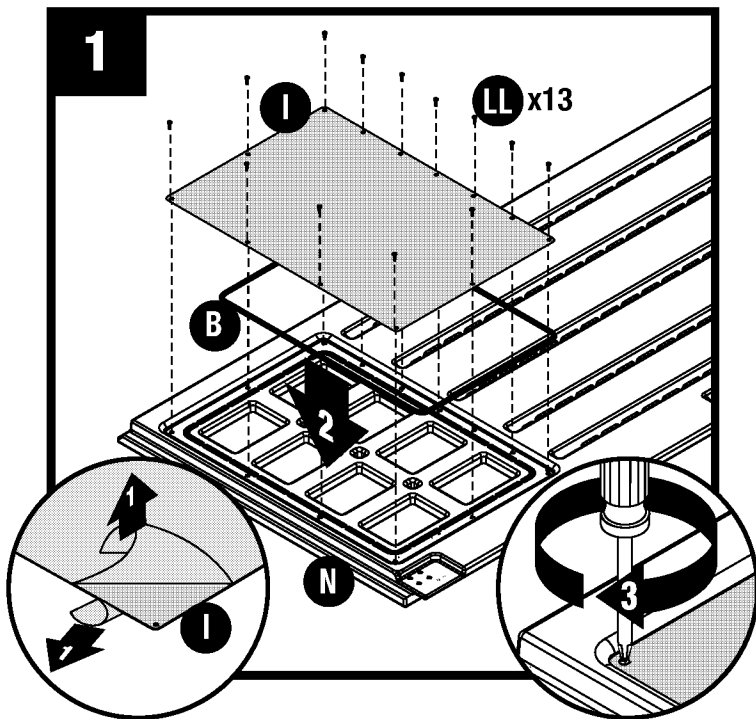

Peel film from both sides of window (I).

Lay left door (N) on flat ground with window screw attachments facing up. Place window gasket (B) into door channel, then place window (I). Cut excess gasket length. Through backside of door, secure layers with thirteen screws (LL)—start with four corner screws and then finish with remaining screws. **DO NOT** over tighten screws. Repeat on right door (M).

Note: The cut portion of window gasket (B) **MUST** be assembled on top of door channel.

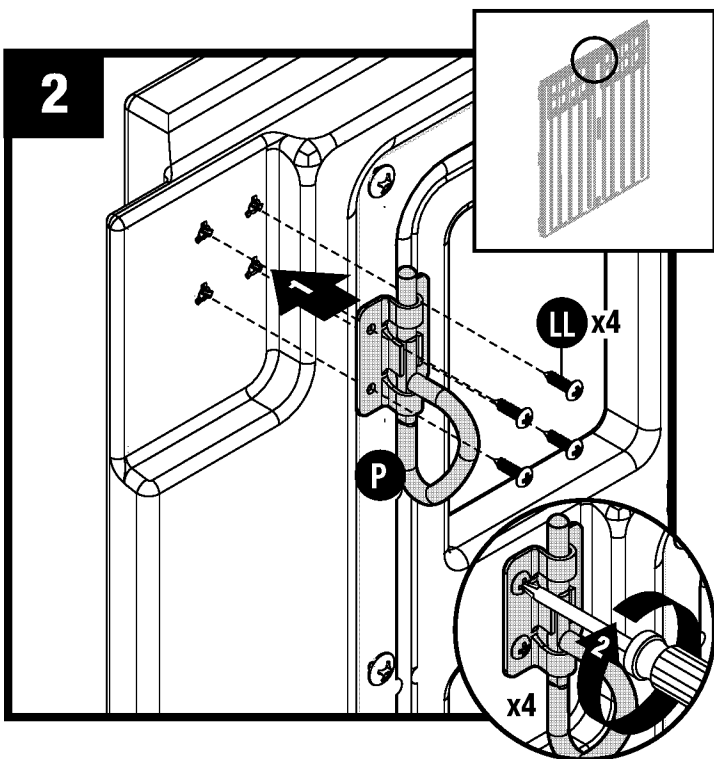

At top interior side of left door, attach D-ring slide bolt (P) with four screws (LL) through provided holes.

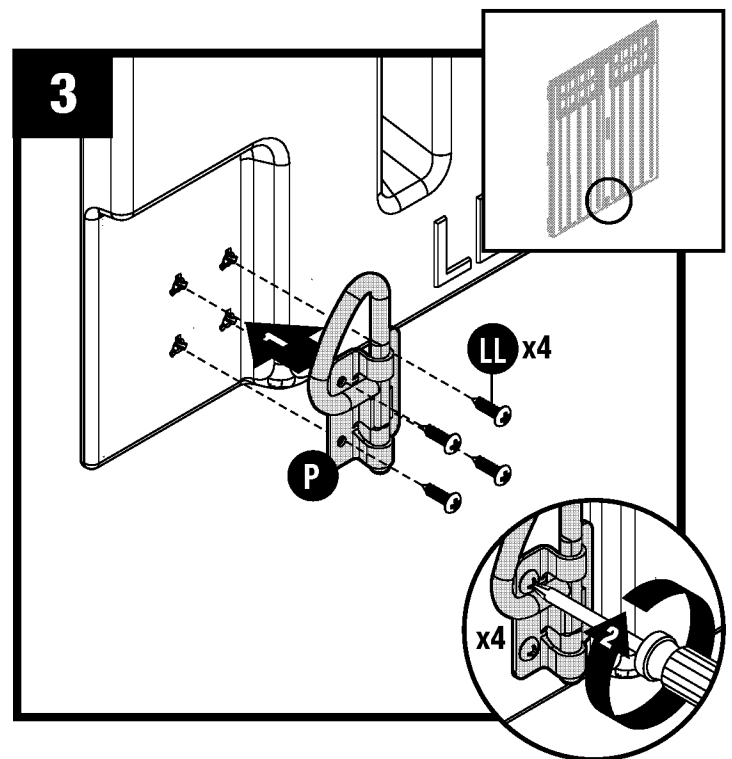

At bottom interior side of left door, attach D-ring slide bolt (P) with four screws (LL) through provided holes.

Header Pre-Assembly

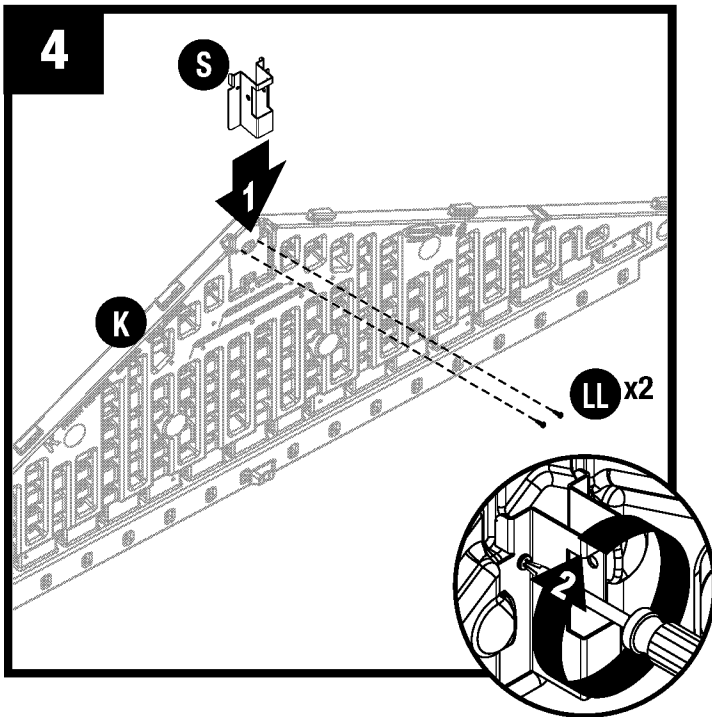

Slide roof ridge beam bracket (S) under tabs on inside peak of front header (K) and secure with two screws (LL). **DO NOT** over tighten screws.

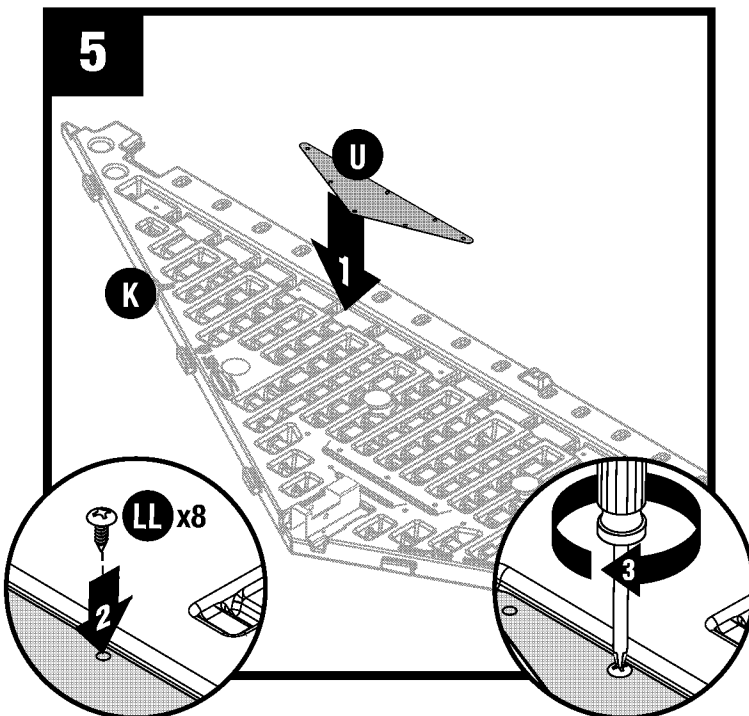

Lay front header (K) on ground with lettering facing up. Place vent screen (U) into rear opening in front header (K). Secure through back of header with eight screws (LL). **DO NOT** over tighten screws.

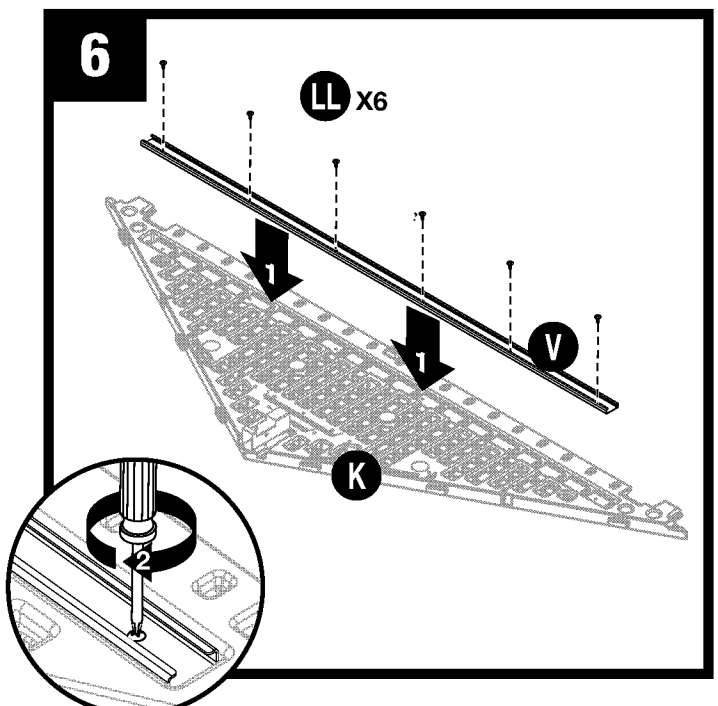

Insert header beam (V) into header (K). Attach using six screws (LL). **DO NOT** over tighten screws.

Repeat steps 4-6 for rear header (AA).

Truss Pre-Assembly

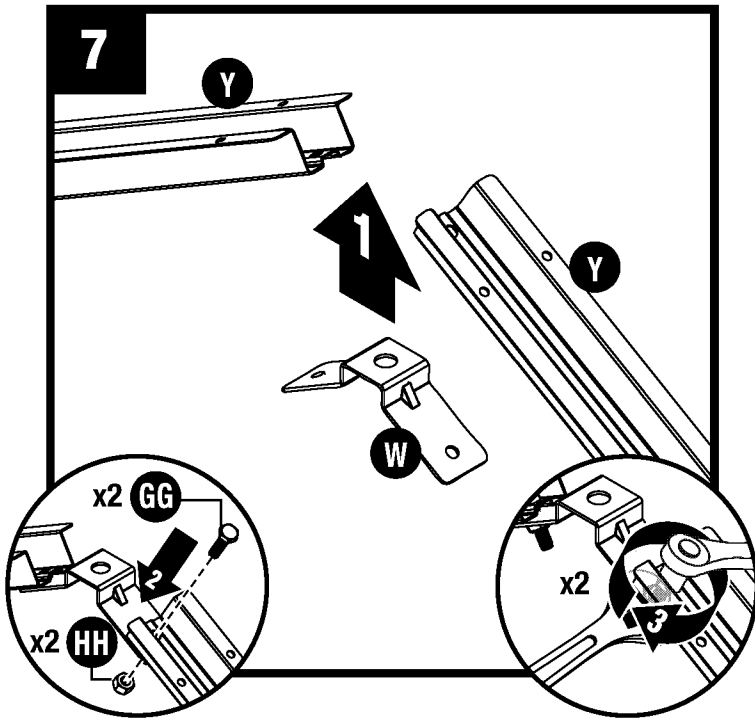

Attach truss bracket (W) to end of one truss leg (Y) with 1" hex bolt (GG) and nut (HH). REPEAT WITH OTHER TRUSS LEG.

Note: Make sure side hole is at other end, as shown in step 8.

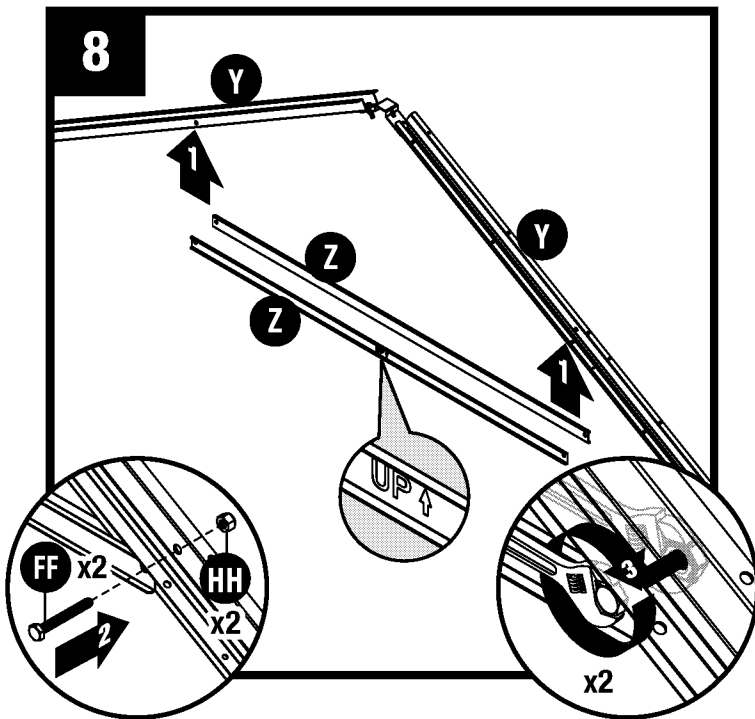

Attach truss cross beam (Z) to two truss legs (Y) using two hex bolts (FF) and two nuts (HH). Stand truss and check cross beam is level.

Truss Pre-Assembly (continued)

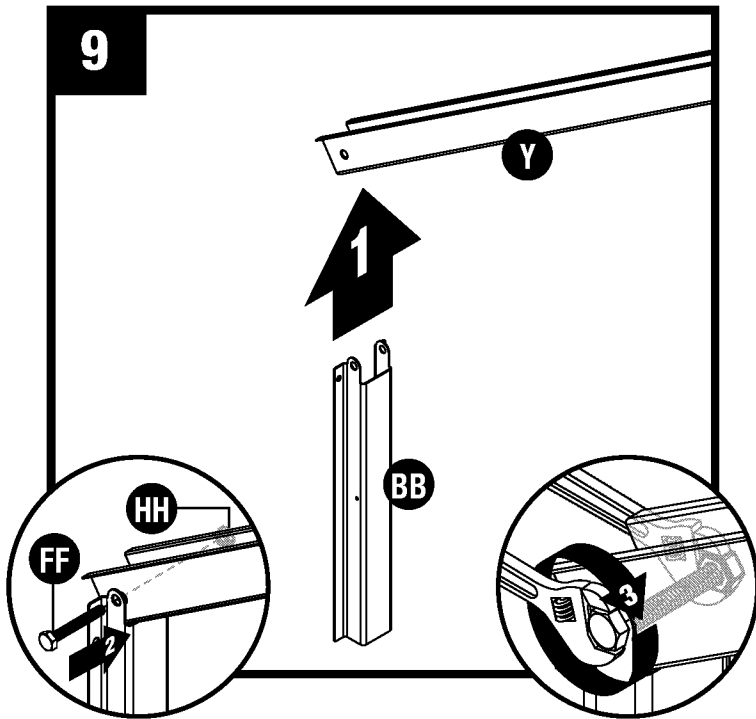

Place side adaptor bracket (BB) at end of left truss leg (Y). Secure adaptor bracket with one 2" hex bolt (FF) and one nut (HH). Repeat for remaining side adaptor bracket (BB).

Note: DO NOT over tighten side adaptor bracket (BB) onto end of truss leg (Y). Roof panels will assemble to truss legs (Y) in later step. After shed assembly is completed, check that all hardware is securely fastened.

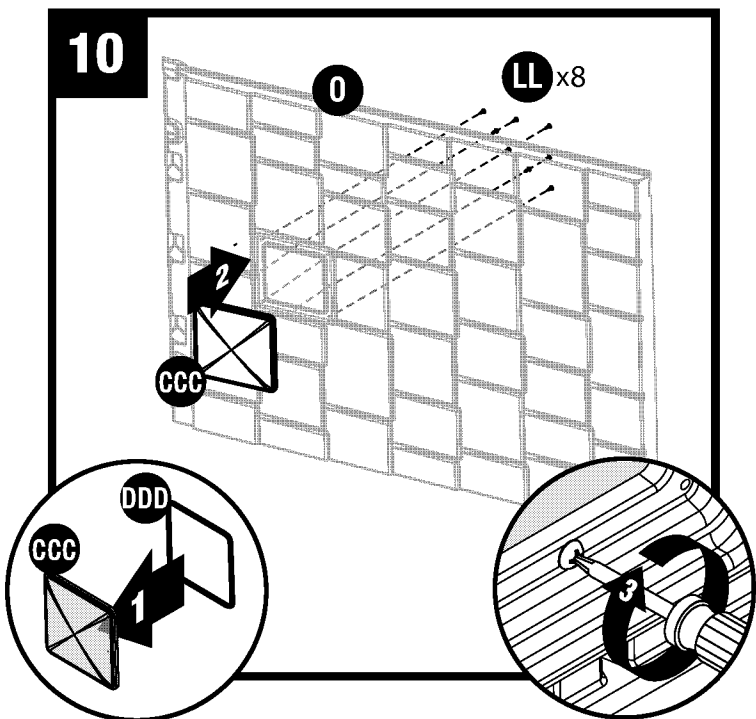

Place skylight gasket (DDD) into skylight (CCC). Place skylight (CCC) onto right roof panel (O). Secure from underside with eight screws (LL). Make sure rib on roof panel is seated fully against gasket on skylight. Repeat for remaining roof panels.

Shed Assembly/Walls

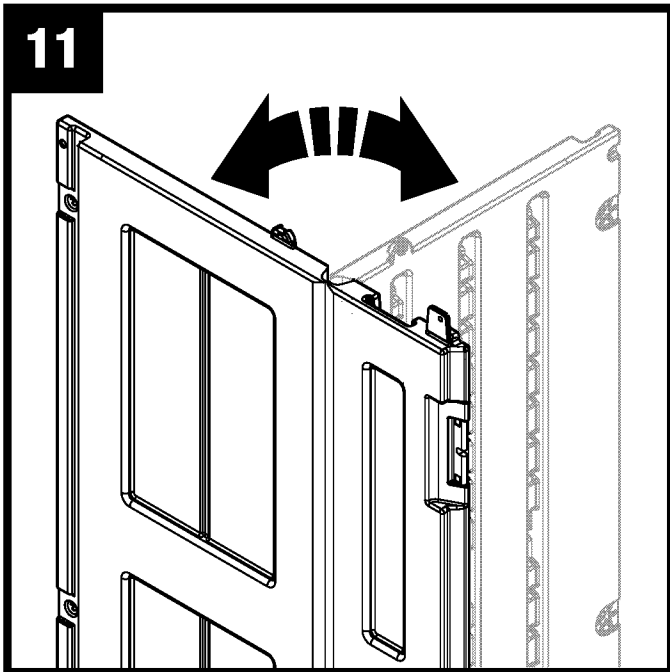

Critical: When installing corners, flex corner hinges back and forth several times. This will help provide a square corner and ensure proper fit of remaining panels.

Important: DO NOT flex in reverse position, as this can crack the panel.

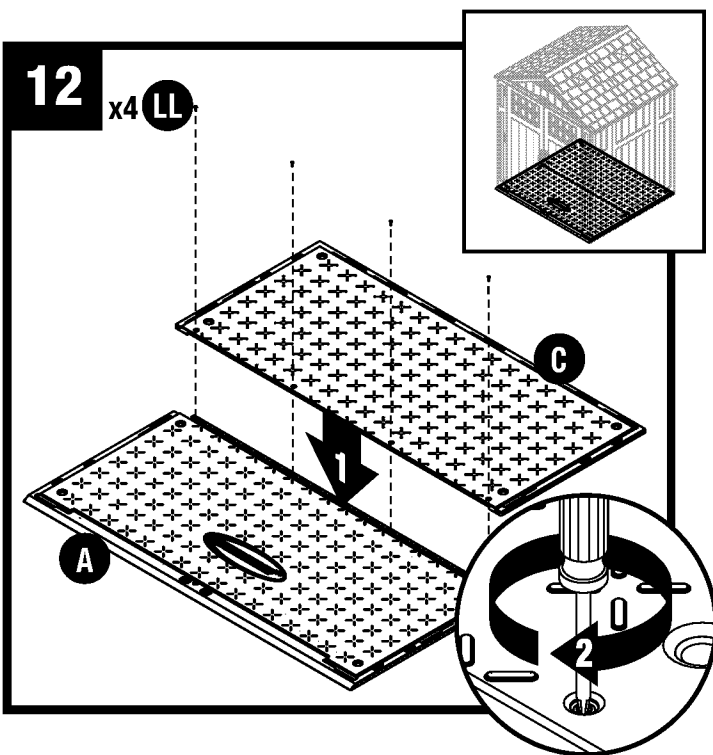

Push front floor (A) and rear floor (C) panels together and secure with four screws (LL).

Note: Refer to pages 9 and 10 to secure floors to foundation.

Shed Assembly/Walls (continued)

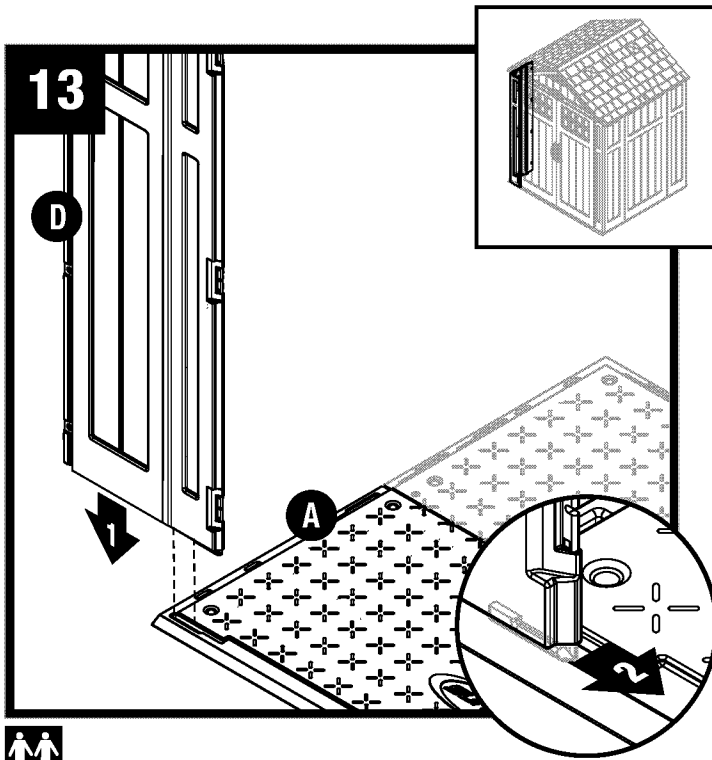

Align tab on bottom right side of left front corner (D) with slot on front floor (A). Lower panel into slot and lock in place by sliding panel toward door opening.

Note: Use a rubber mallet to “push” left front corner (D) into locked position.

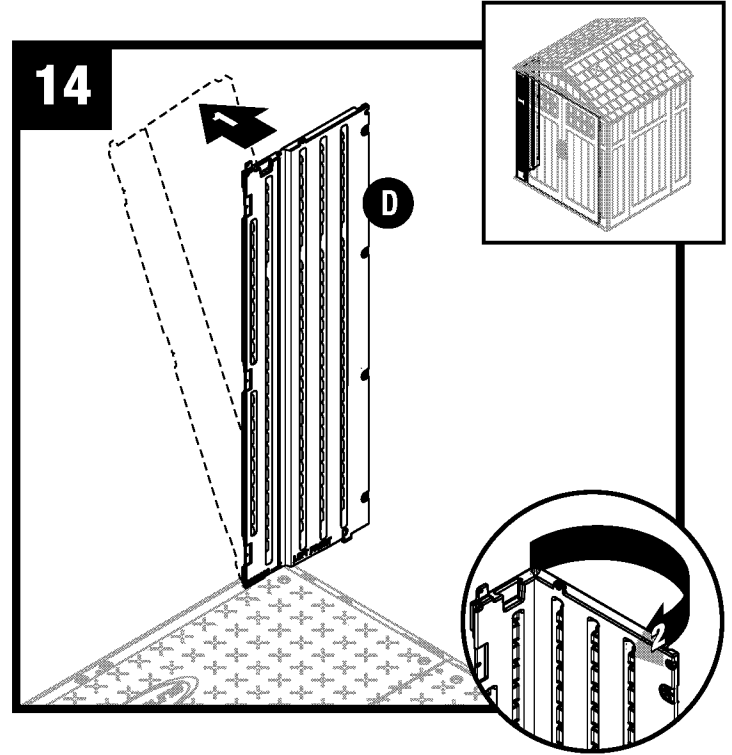

Tip left front corner (D) back to vertical position and align lower tabs on right side with slots in floor.

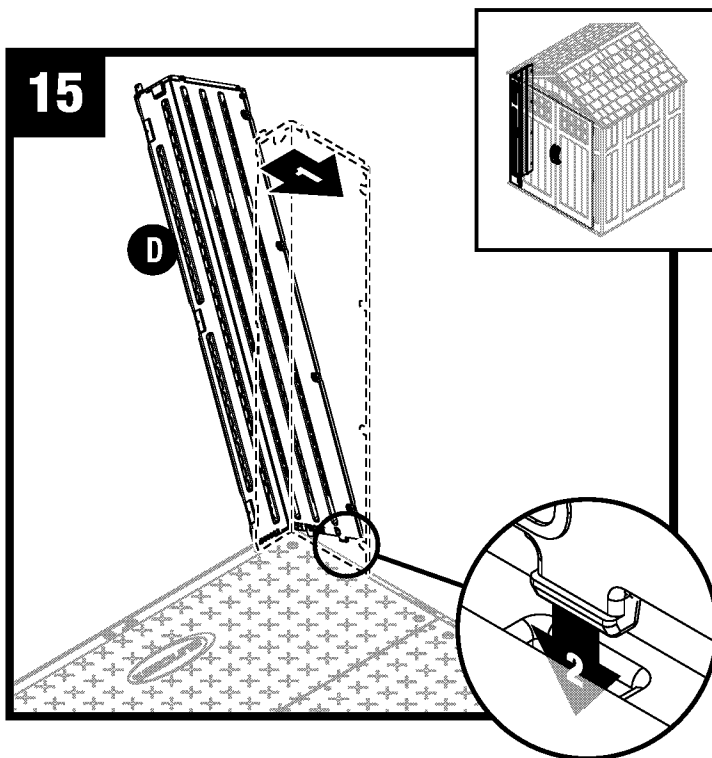

Tip left front corner (D) back to vertical position and align lower tabs on right side with slots in floor.

Shed Assembly/Walls (continued)

16

Before proceeding, make sure corner is square (top view) where it meets the floor and that panel is flush (side view) with floor.

If not, repeat Steps 13–15 until square and flush.

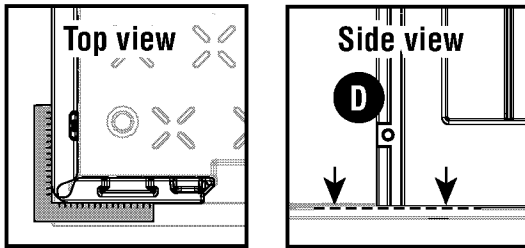

17

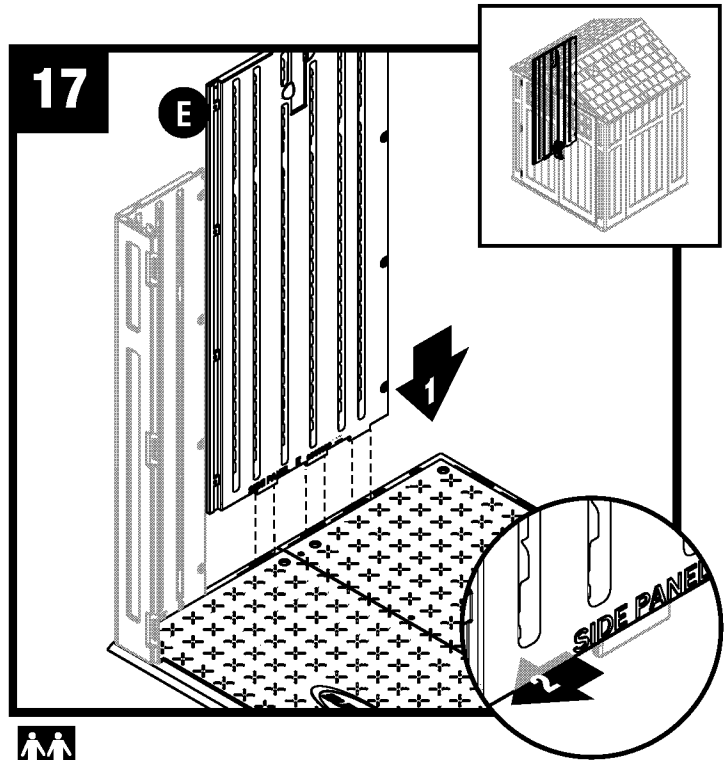

Align tabs on bottom of side panel (E) with slots along front and rear floors. Lower panel into slots and lock in place by sliding panel toward front corner.



Note: Use a rubber mallet to “push” side panel (E) into locked position.

18

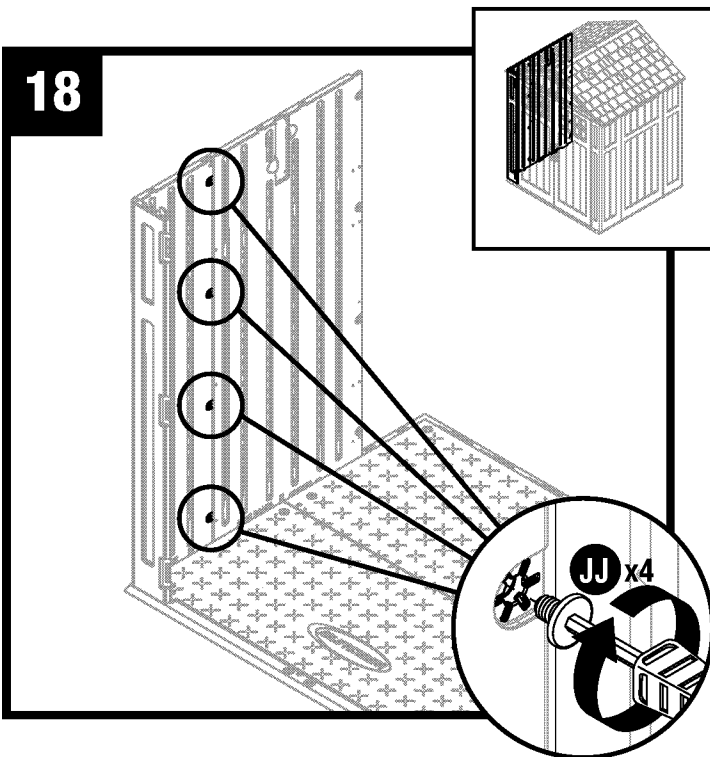

Secure side panel with four easy bolts (JJ), working from floor to roof. **DO NOT** use torque wrench. Use easy bolt easy driver (KK) and hand tighten. Easy bolt head will be flush when fully seated. **DO NOT** over tighten easy bolts.

Note: You may hear a click when easy bolt has been tightened completely.

19

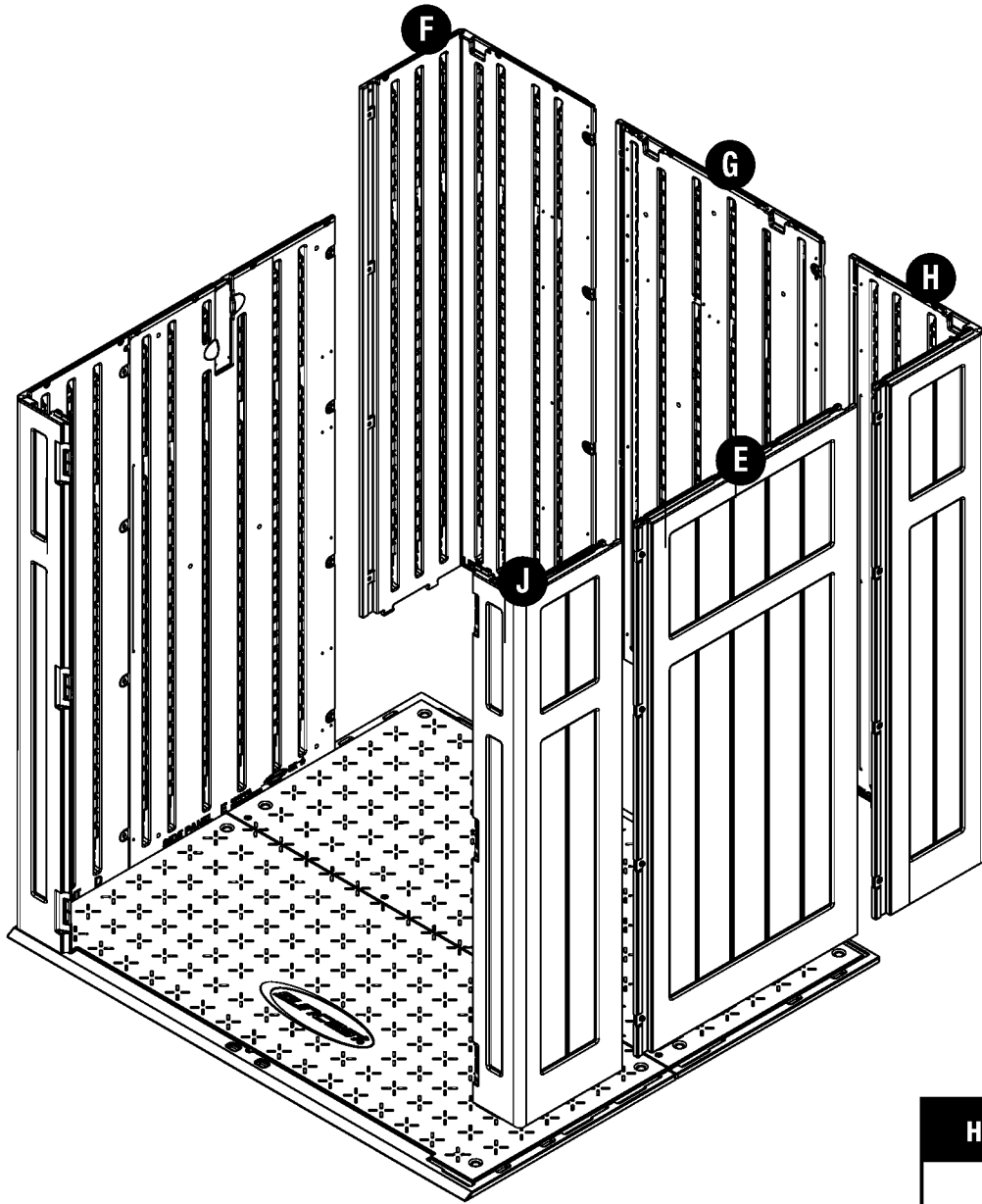
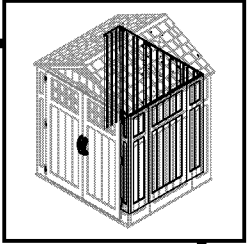

Hardware Needed

JJ x20

Repeat Steps 13-18 for remaining panels.

Shed Assembly/Headers

20

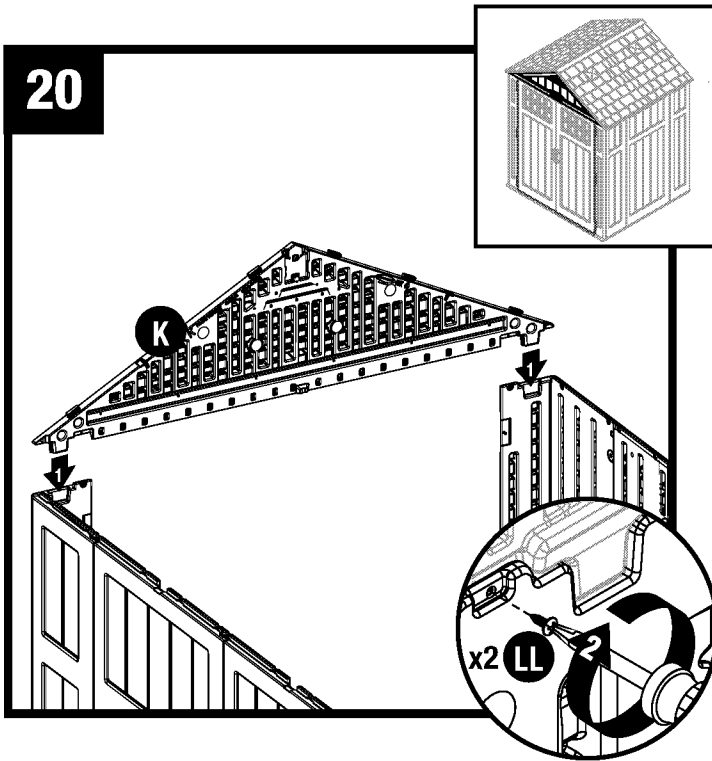

Place front header (K) over door opening and fit the two protruding support legs on left and right front corners into pockets molded in front header. Tabs on front header must be seated in header channel pocket. Secure front header using two screws (LL).

21

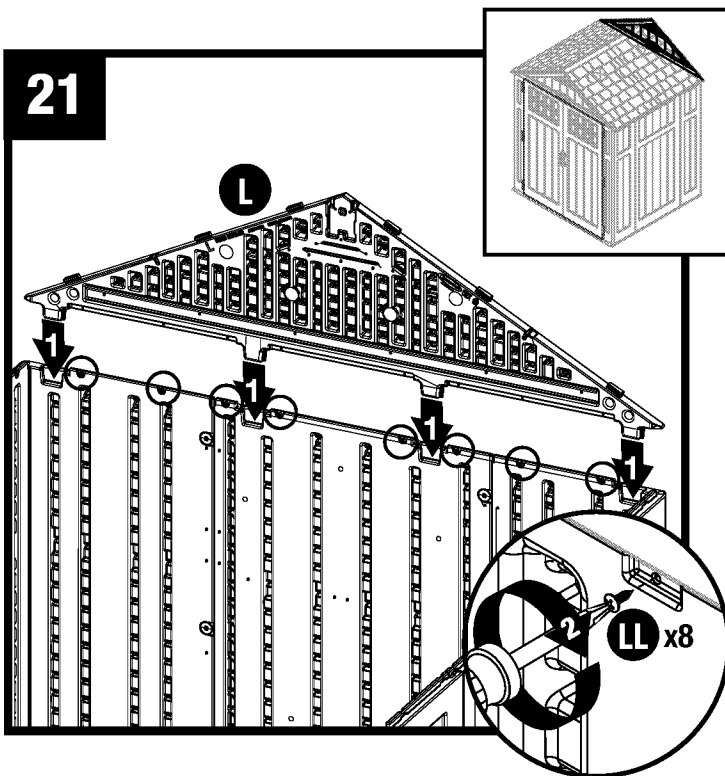

Place rear header (L) over back walls and fit the two protruding support legs on left and right back corners into pockets molded in rear header. Tabs on rear header must be seated in header channel pocket. Secure rear header using eight screws (LL).



Shed Assembly/Headers (continued)

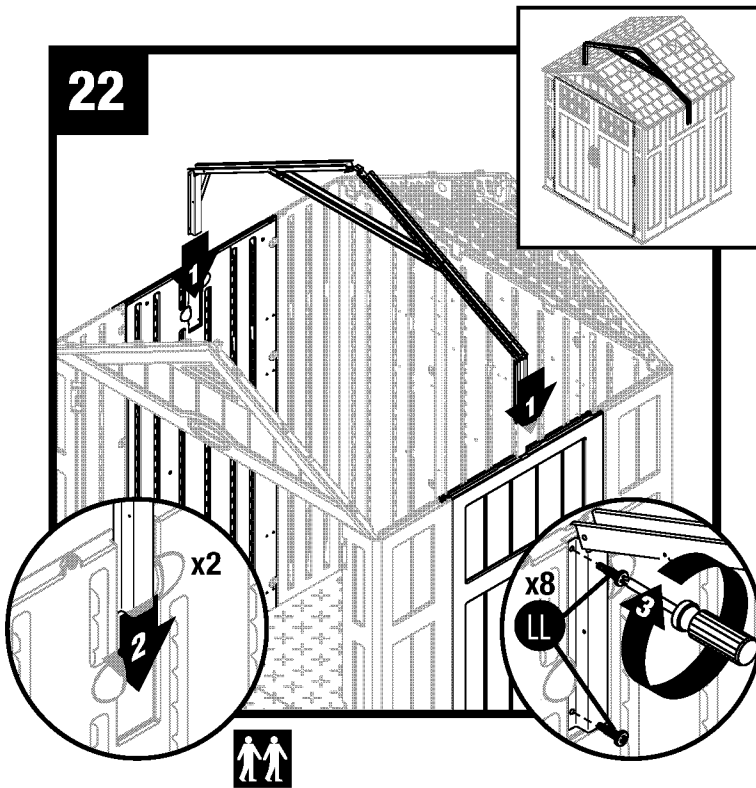

Slide truss assembly into place. Secure to side panels with four screws (LL) in each side adapter bracket.

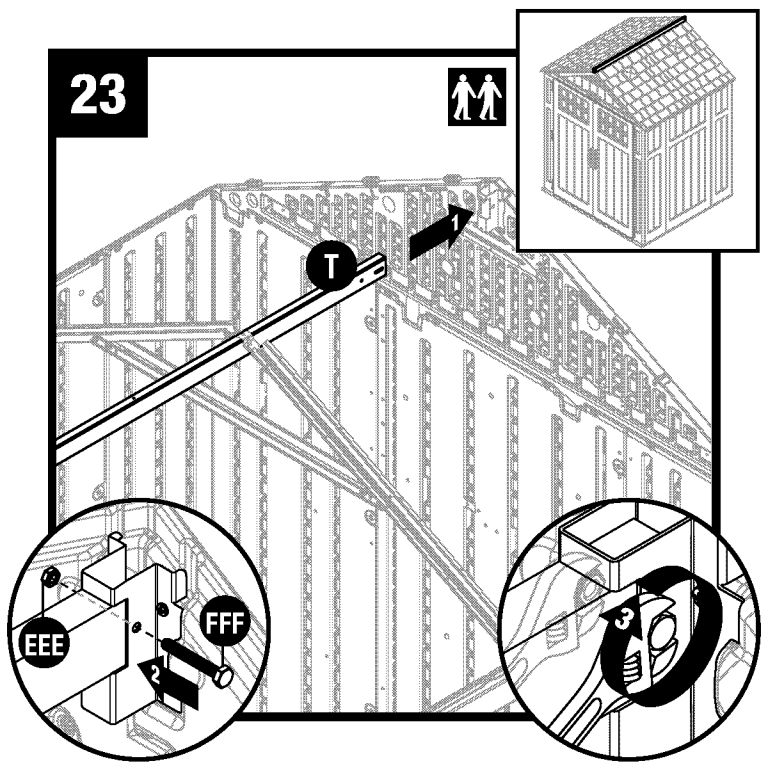

Raise ridge beam (T) up and into rear roof ridge beam bracket. Secure with one 2" hex bolt (FFF) and one nut (EEE).

Note: Alignment of ridge beam to bracket may require header panels to be pushed inwards or outwards slightly as ridge beam is slid into place.

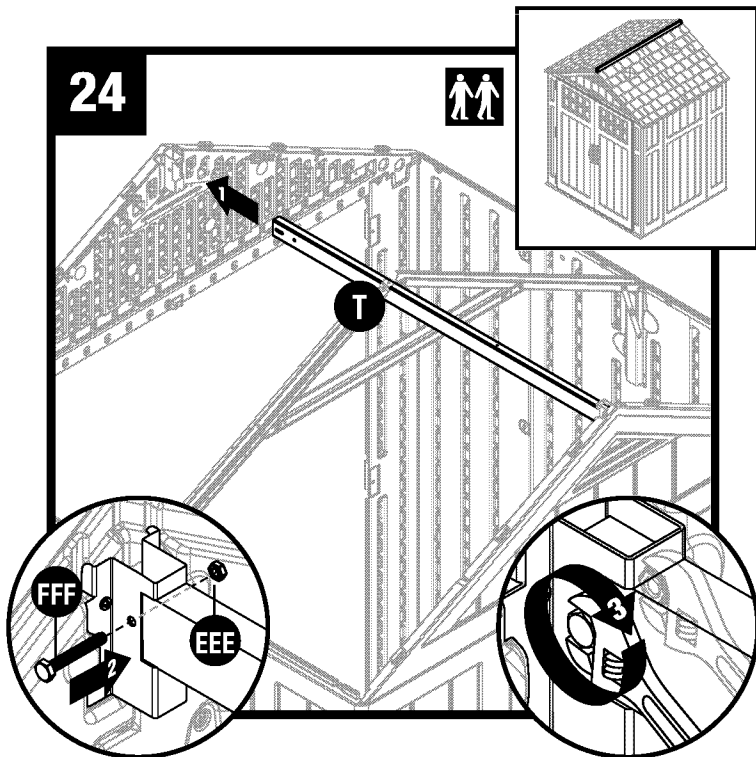

Slide ridge beam (T) into front roof ridge beam bracket. Secure with one 2" hex bolt (FFF) and one nut (EEE).

Note: Alignment of ridge beam to bracket may require header panels to be pushed inwards or outwards slightly as ridge beam is slid into place.

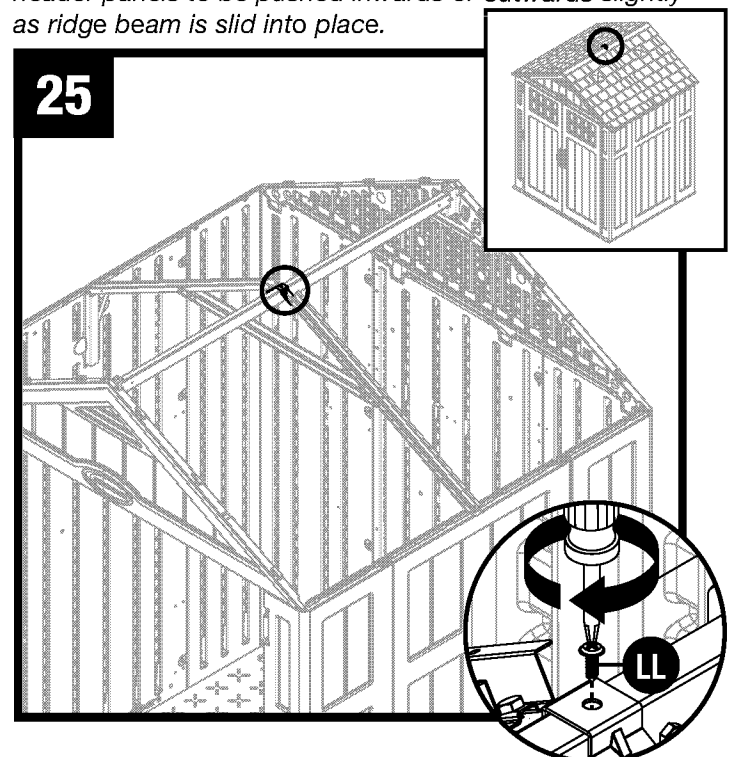

Attach the roof truss assembly to the ridge beam with one screw (LL).

26

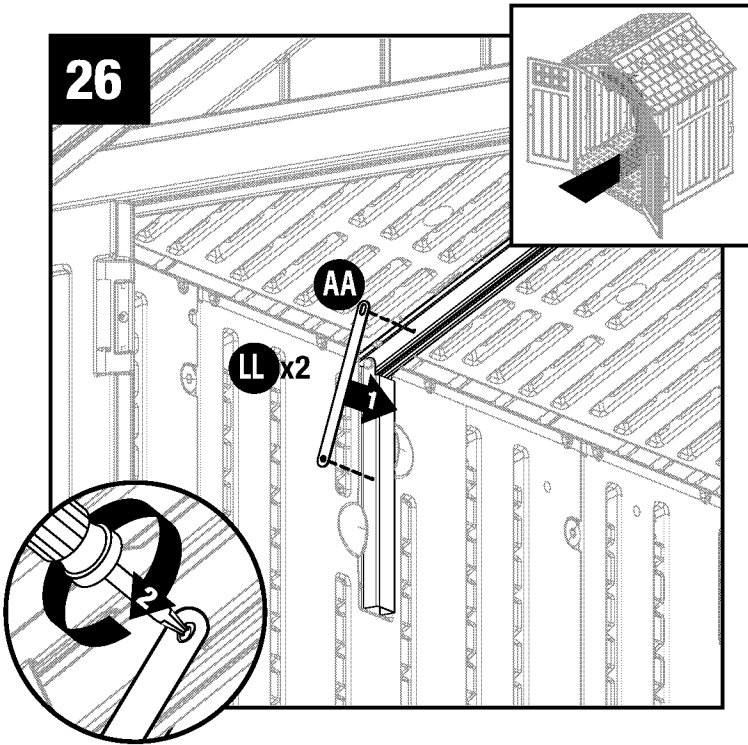

Attach one truss strap (AA) at each end of truss legs. Secure each truss strap with two screws (LL). Repeat for remaining truss straps.

Shed Assembly/Roof

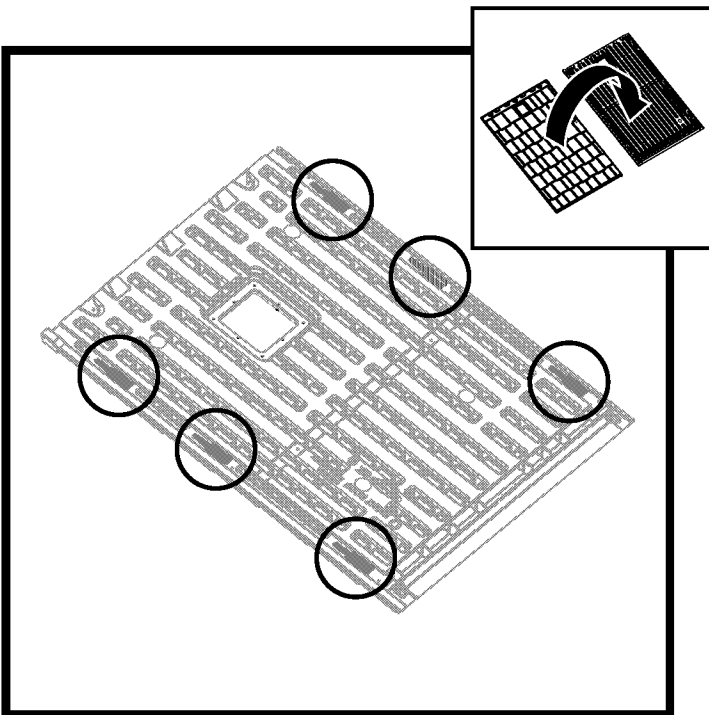

Before proceeding, locate and identify the six slots on interior side of right and left roof panels.

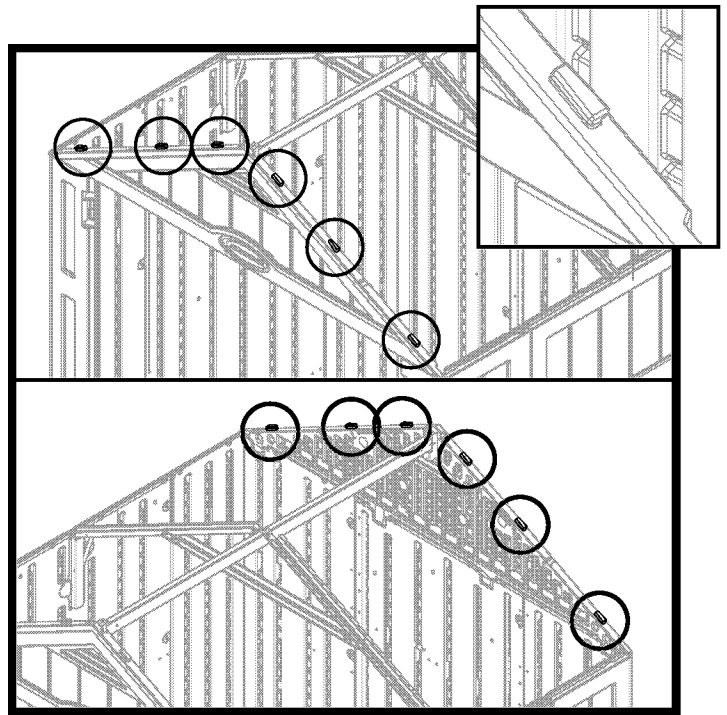

Before proceeding, locate and identify the six front header tabs and six rear header tabs.

Shed Assembly/Roof (continued)

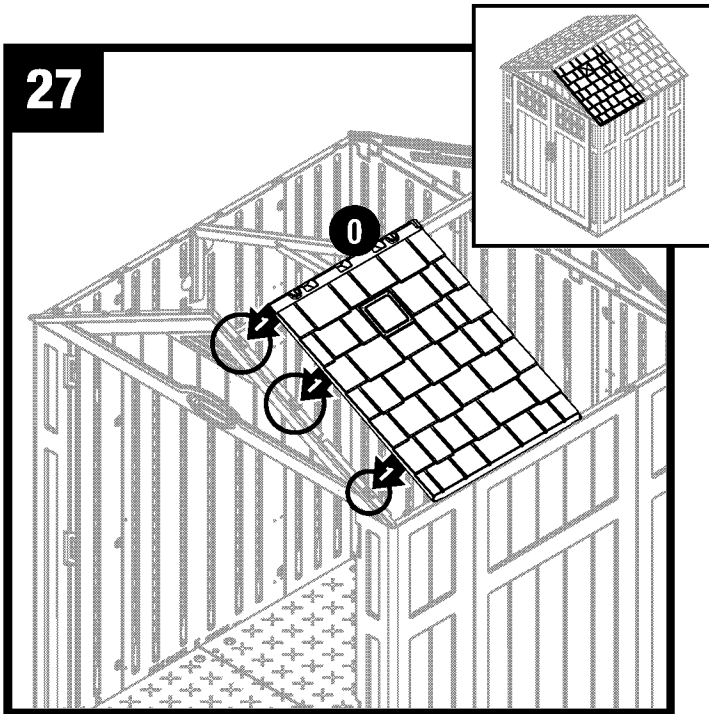

Lay right roof (O) directly over the three tabs on right side of front header (K). With right roof slots seated over/on header tabs, check alignment in all three spots.

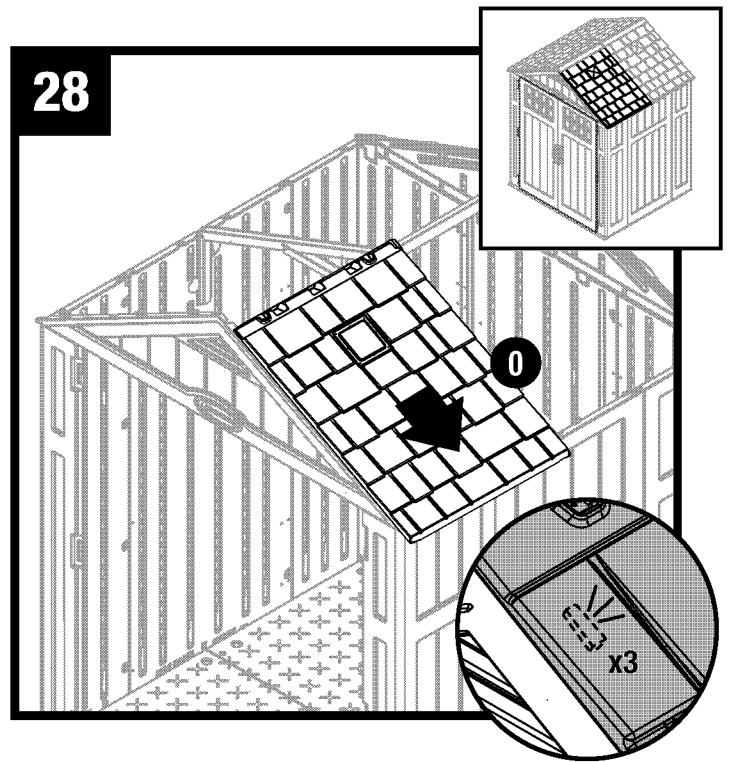

Slide right roof (O) down towards the outside of shed. You will hear a "snap" when engaged.

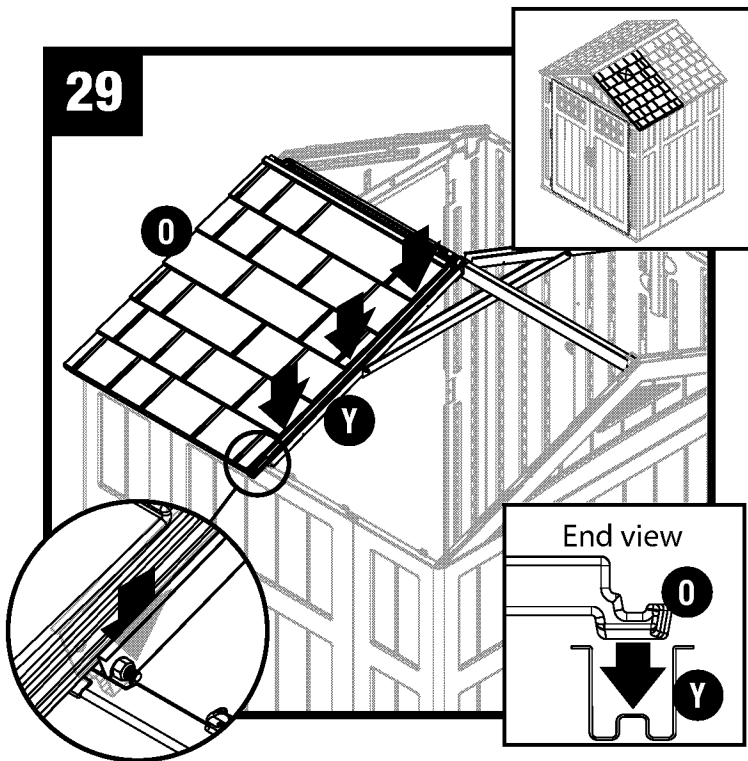

Press edge of right roof (O) into channel on truss leg (Y).

Shed Assembly/Roof (continued)

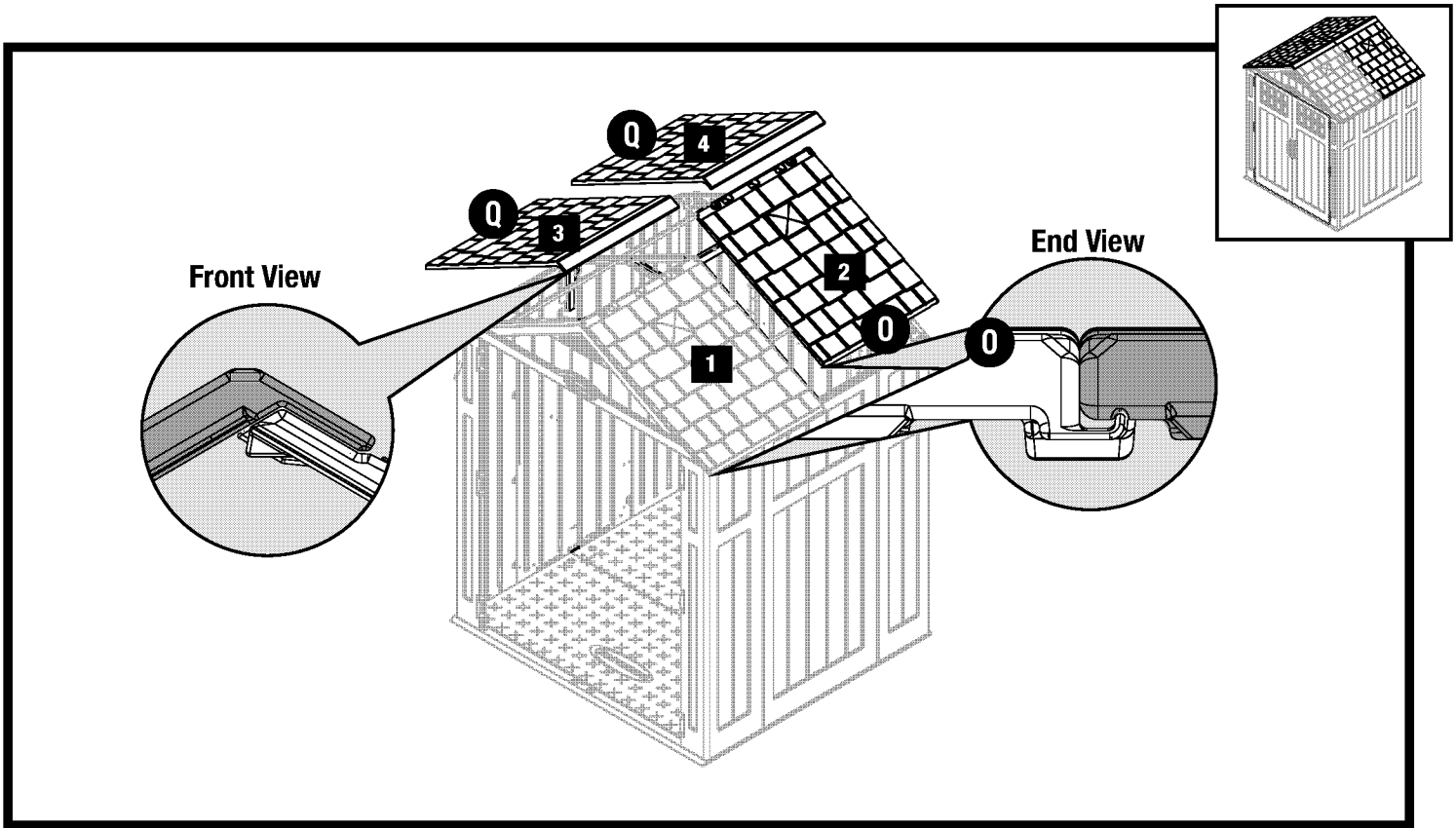

Repeat Steps 27-29 for remaining roof panels. Install panels in the order shown.

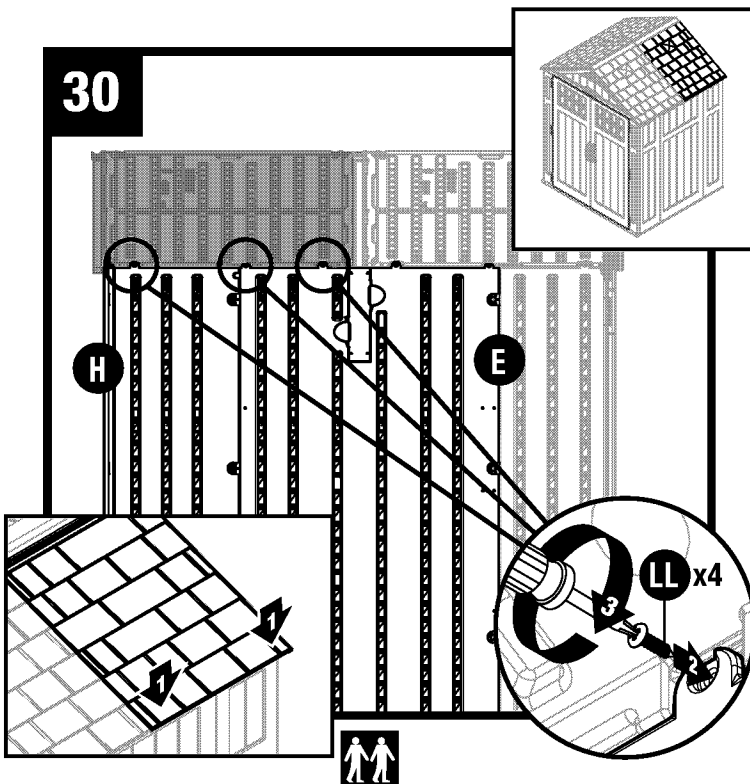

Pull down each lower corner of roof from outside. From inside shed, attach tabs on back corner (H) and side panel (E) roof panel with four screws (LL).

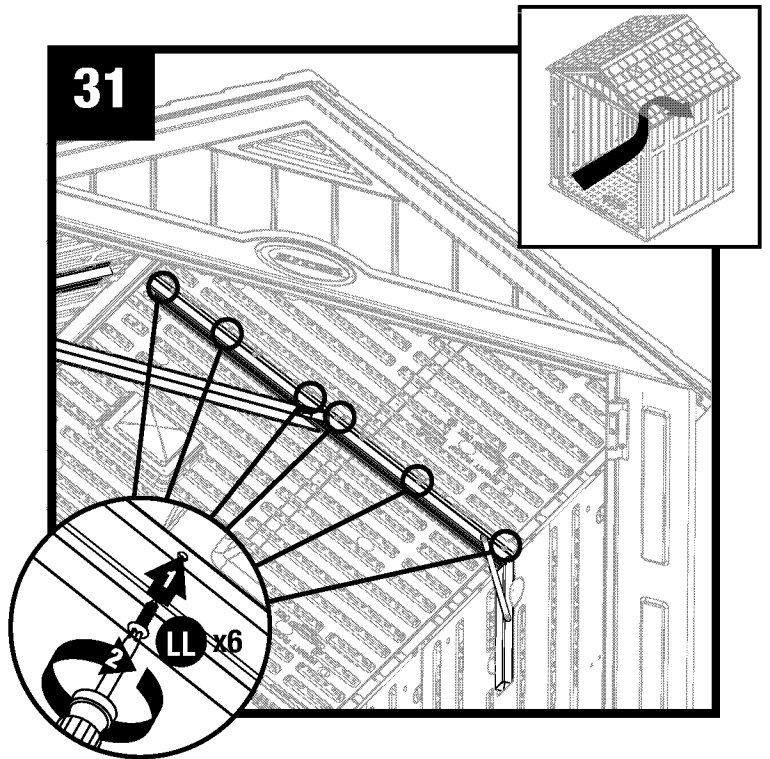

Secure roof to truss using six screws (LL). Each screw will attach at a corresponding screw boss on the roof.

Shed Assembly/Roof (continued)

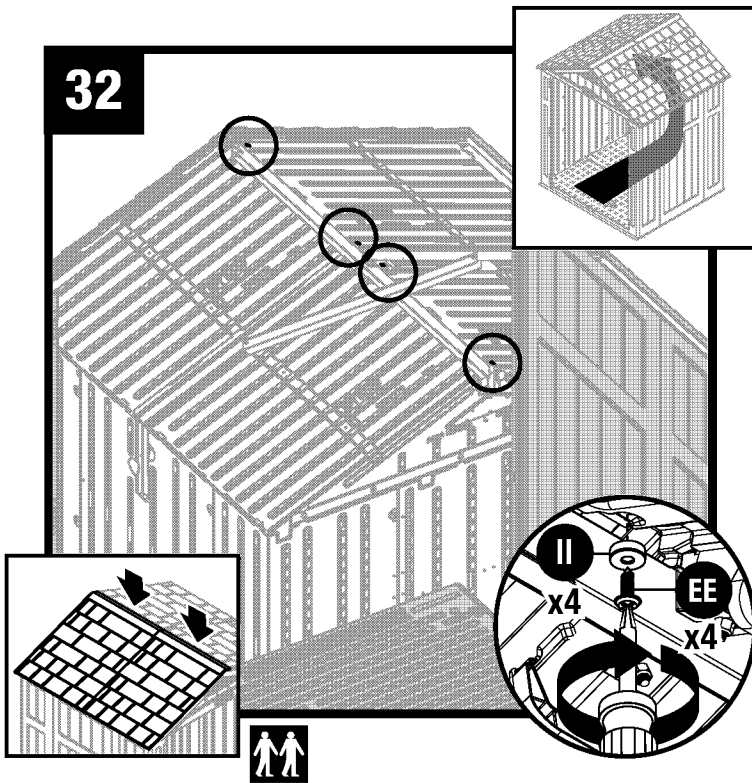

Push down the roof from outside. From inside shed, secure roof panels together along ridge of roof using four rubber washers (II) and four sealing screws (EE).

Note: For clarity, illustration is shown with front header, right front corner removed.

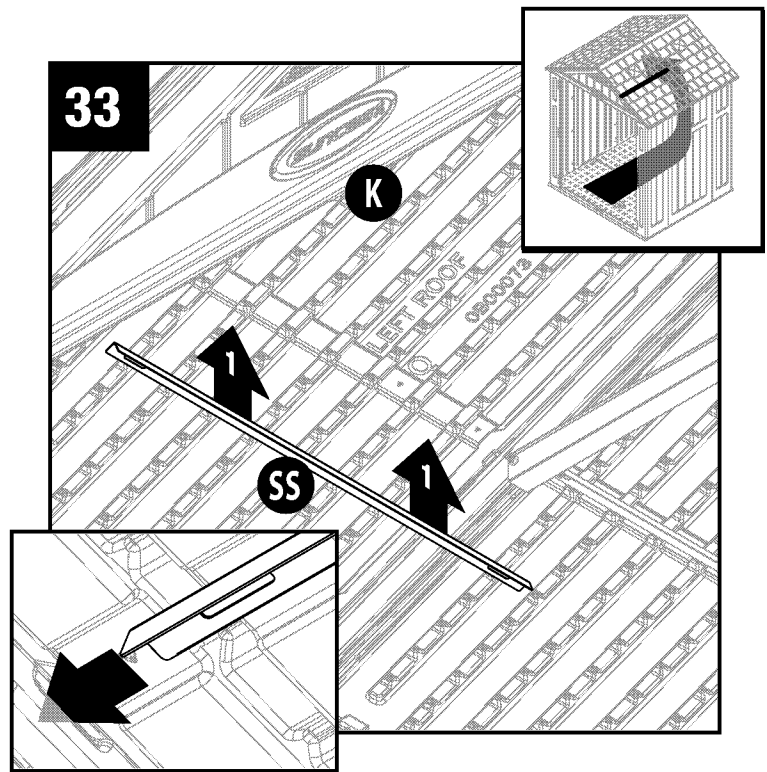

Raise front roof support bracket (SS) into position against roof. Slide front roof support bracket (SS) into front header (K).

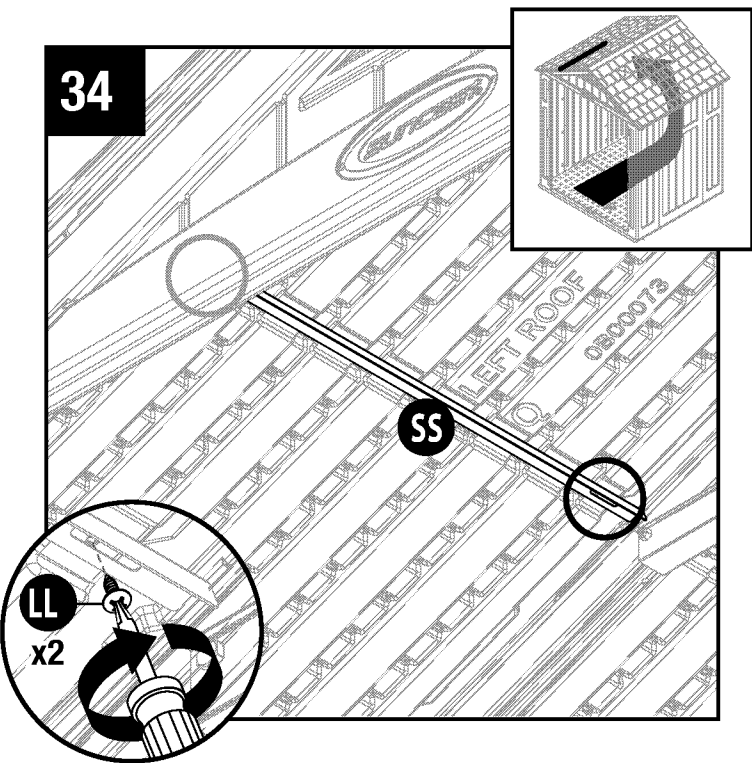

Secure front roof support bracket (SS) to underside of roof using two screws (LL). Repeat steps 33-34 for remaining roof support brackets.

Shed Assembly/Doors

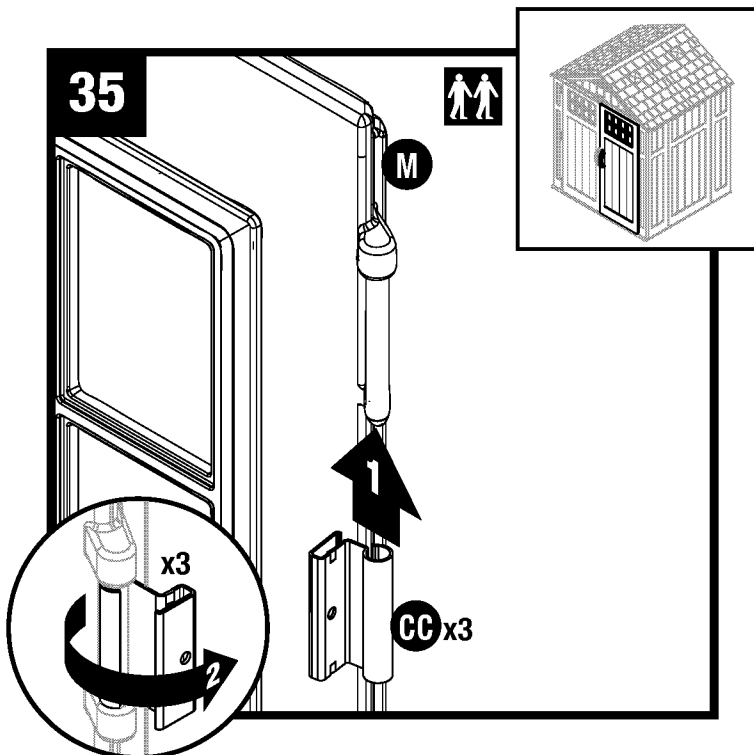

Stand right door (M) upright with three hinge mounts facing right. Slide one metal hinge plate (CC) onto each hinge mount. Rotate hinge plates to outside of door.

Repeat for left door (N).

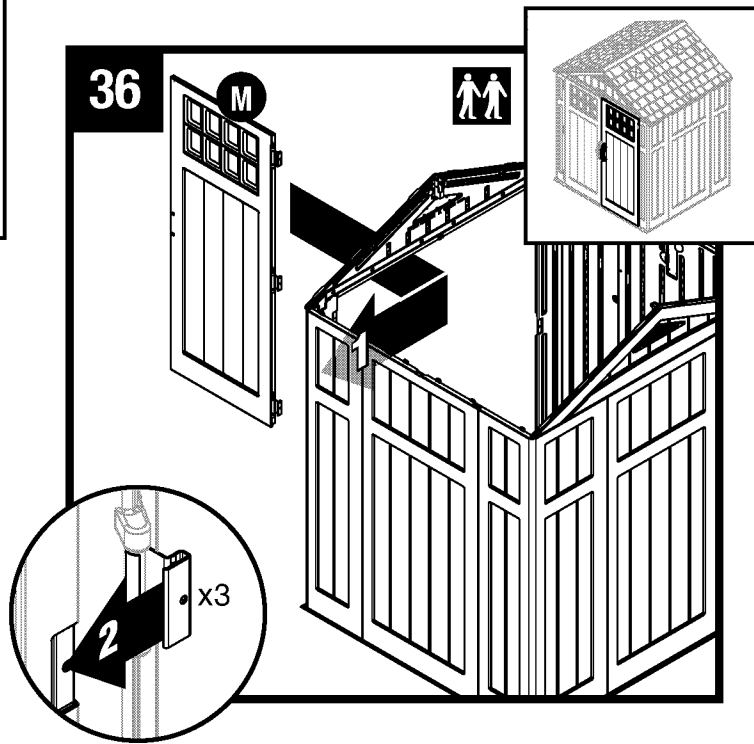

With metal hinge plates in open position, slide one metal hinge plate over each hinge receptacle on inside of right front panel.

Note: For clarity, illustration is shown with roof and ridge beam removed.

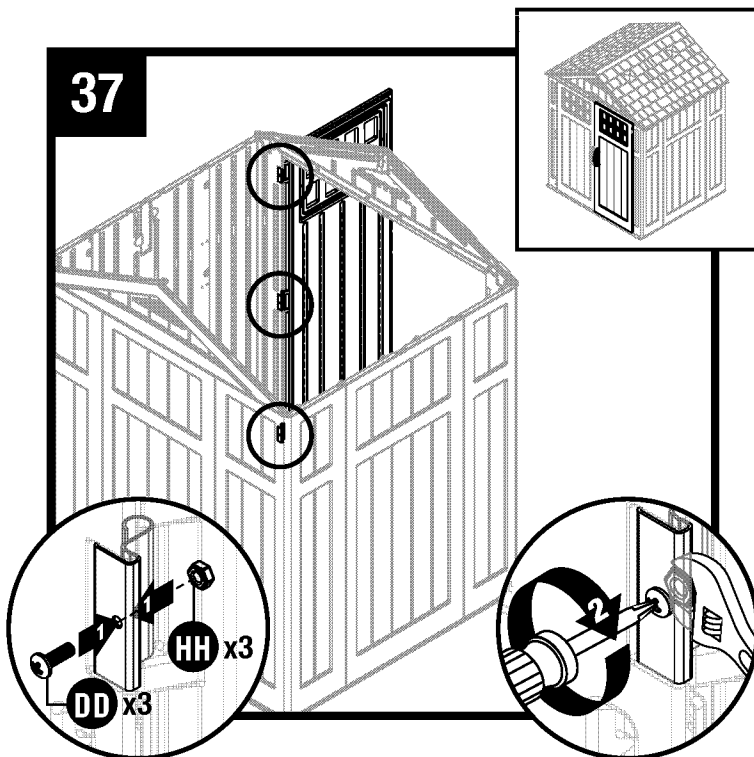

Secure each metal hinge plate with one screw (DD) and one nut (HH).

Repeat Steps 35-37 for left door (N).

Note: For clarity, illustration is shown with roof and ridge beam removed.

Shed Assembly/Doors (continued)

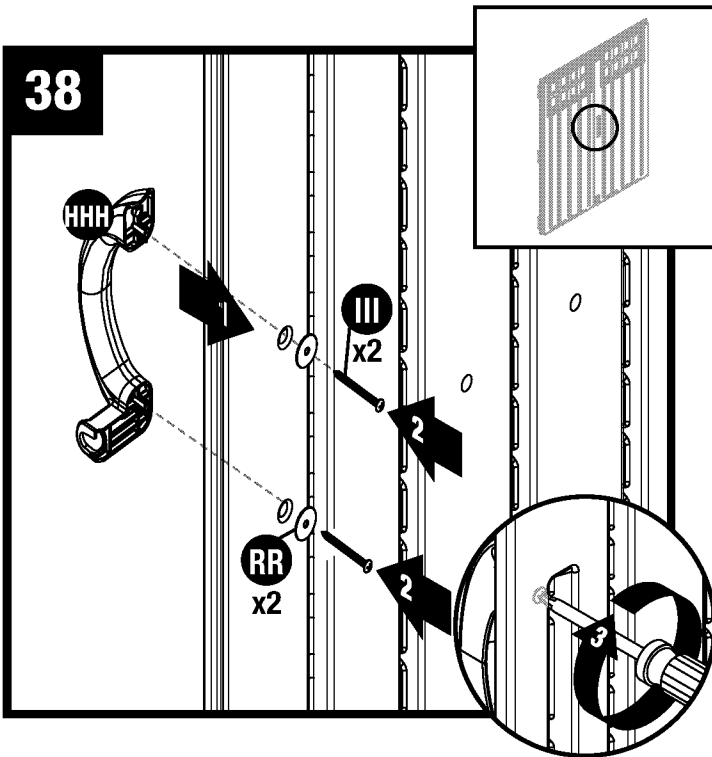

Attach door handle (HHH) to left door with two screws (III) and two washers (RR). Repeat for right door.

Repeat for right door.

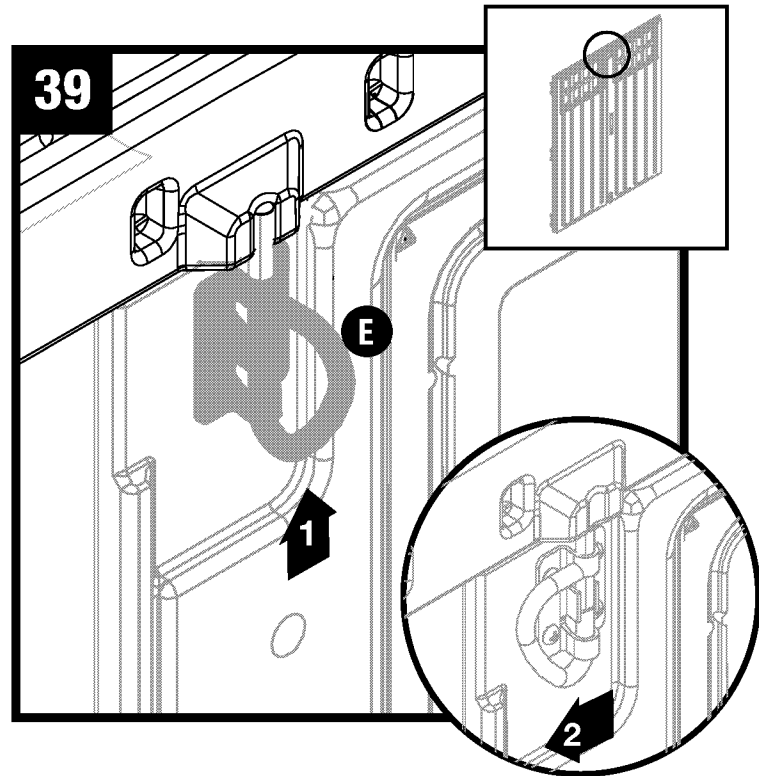

Lift D-ring (E) up to engage with slot in header. Turn D-ring to left for locked position.

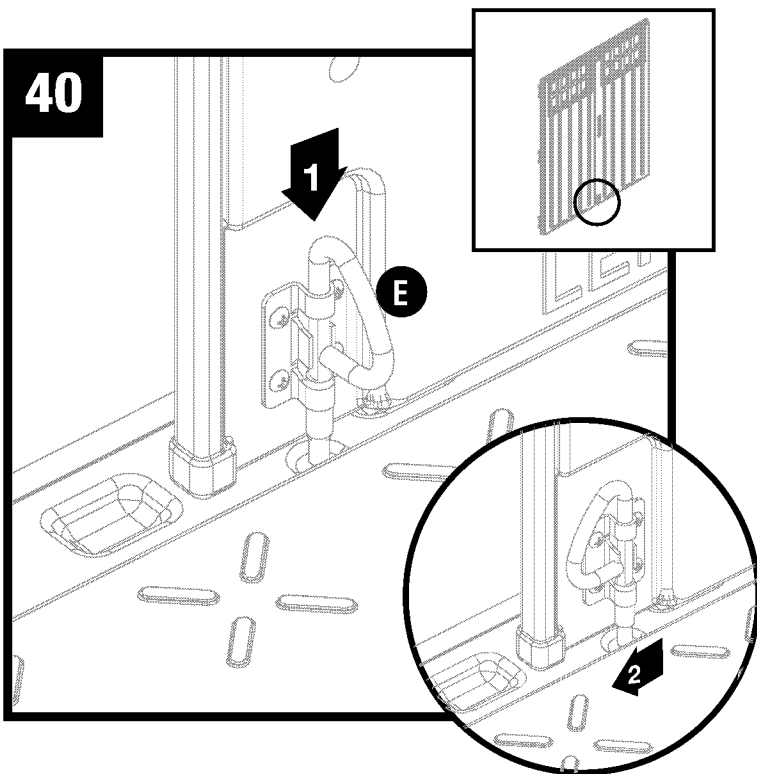

Push D-ring (E) down to engage with hole in floor. Turn D-ring to left for locked position.

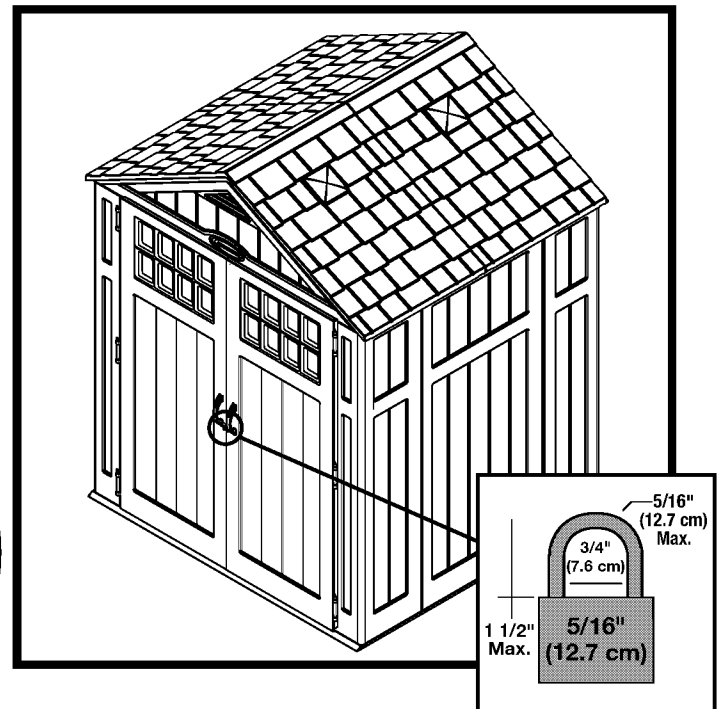

Attach a 5/16" lock (not provided) to door handles, to properly secure shed.

Warranty

SUNCAST® Building, Shed and Gazebo Ten Year Limited Warranty

Your SUNCAST® Building, Shed or Gazebo has a TEN YEAR LIMITED WARRANTY against product failure resulting from defects in manufacturing or materials. The warranty period starts on the delivery date. Incidental and consequential damages are not covered.

Warranty Claims

To file a warranty claim contact the manufacturer, SUNCAST® CORPORATION, 701 North Kirk Road, Batavia, Illinois, 60510. Call toll free (800) 846-2345 or visit www.Suncast.com.

SUNCAST® will repair or replace only the parts that failed under the terms of the warranty. In some cases, the replacement parts may not be identical, but they shall be of equal or greater performance than the original part.

We may require proof of purchase. Proof of purchase may be the original dated store receipt. We may require evidence of the failure. Evidence of failure may include photographs or returning failed components to SUNCAST.

WARRANTY LIMITATIONS

THIS WARRANTY COVERS ONLY DEFECTS THAT AFFECT THE FORM, FIT OR FUNCTION OF THE UNIT. It excludes natural aging of the unit, discoloration, ordinary wear and tear, ordinary weathering, sunlight fading, or rust. It excludes staining caused by mold, mildew or tree sap and damage caused by animals including insects, vermin or household pets. The warranty does not cover damage caused by Acts of Nature including but not limited to: wind in excess of 65 mph; tornado; hurricane; microburst; hail; flood; blizzard; extreme heat; pollution or fire events. For all storm and windy conditions, the doors must be closed, latched, and a padlock used through the door handle padlock receptacles. Left and right doors may have different latches, and both must be engaged. Latching devices vary by model. The warranty does not cover damage caused by Sun energy reflected from "Low-E" windows or other reflective materials. The user is responsible for protecting the product from damage in this situation.

The following actions void the warranty: improper assembly; assembly on a foundation other than as described in the assembly instructions; use above intended and reasonable capacity; misuse; abuse; failure to perform ordinary maintenance; failure to remove snow over 8 inches deep; modification; cleaning with abrasive tools, exposing the unit to heat sources and vandalism. Painting, sandblasting, cleaning with harsh chemicals not recommended for plastics voids the warranty on resin components. Modification of the original product voids all warranties. Suncast assumes no liability for any modified product or consequences resulting from failure of a modified product. Damage due to moving, transporting, or relocating the product voids the warranty. Disassembly of this unit for reasons other than authorized repair voids the warranty.

Suncast is not responsible for: loss of use of the unit; labor for repair; inspection fees or disposal costs.

SUNCAST® reserves the right to reimburse the owner the purchase price of the unit on a STRAIGHT LINE DEPRECIATED BASIS FOR THE LENGTH OF THE WARRANTY IN LIEU OF REPAIR OR REPLACEMENT. The Purchase Price does not include taxes, delivery charges, site preparation costs, permits, fees, assembly costs, or disposal costs.

THIS WARRANTY IS NONTRANSFERABLE. IT IS VALID FOR NORMAL HOUSEHOLD USE ONLY. THE WARRANTY IS VOIDED BY COMMERCIAL OR INDUSTRIAL USE. IT EXCLUDES FLOOR MODELS, CLEARANCE AND OPEN BOX UNITS.

Notice

Suncast® does not represent that this unit will meet city, county, state, homeowner's association standards or zoning requirements. The owner is responsible for securing all permits and meeting other requirements needed for placement, construction and use.

THE MANUFACTURER'S LIABILITY HEREUNDER IS LIMITED SOLELY TO THE REPAIR OR REPLACEMENT OF THE DEFECTIVE PRODUCT OR PART AND THE MANUFACTURER SHALL IN NO EVENT BE LIABLE FOR ANY INCIDENTAL OR CONSEQUENTIAL DAMAGES WHICH MAY RESULT FROM ANY DEFECT IN MATERIAL OR WORKMANSHIP OR FROM THE BREACH OF ANY EXPRESS OR IMPLIED WARRANTY.

This warranty gives you specific legal rights, and you may also have other rights which vary from state to state. Some states do not allow the exclusion or limitation of incidental or consequential damages; the limitation or exclusion may not apply to you.