







# ASSEMBLY INSTRUCTIONS

**ATTENTION: THIS PRODUCT IS NOT FOR COMMERCIAL USE  
INTENDED FOR RESIDENTIAL USE ONLY.**

## TCS26SH

### PARTS LIST

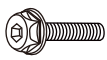
PART NO.	MATERIAL CODE	PART	Q'TY
1	TCS27SH-CS05-1	 TABLE TOP	1
2	TCS27SH-CS04-1	 LEG	4
3	62TCS27HVY101	 CENTER CONNECTOR	1

4	13C??1B29008001	 TILE	4
5	17C40A0705001YX	 BOLT M6*15	12
6	17KAA0101----Y4	 HEX.KEY WRENCH 4MM	1
7	17KAC3101----Y3	 HEX.KEY WRENCH 10MM	1

#### Note:

The tiles are easy to be broken, be careful when you remove them. Do not throw the residual tiles away, retain them for future use.





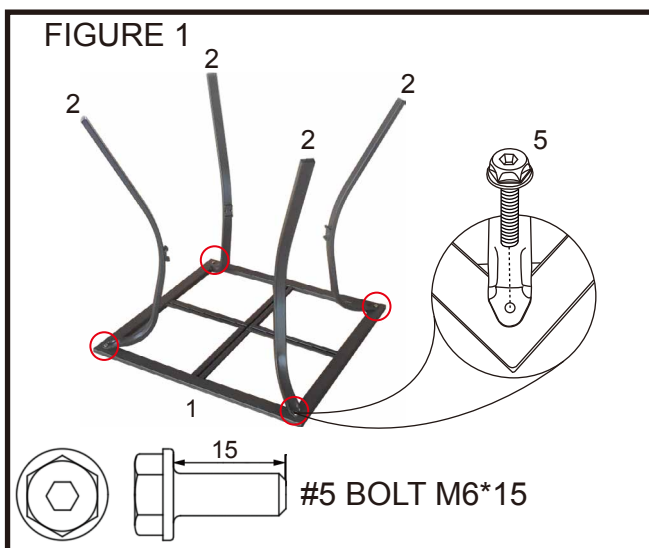

#### Attention:

Make sure that each bolt needed for all steps matches the corresponding figure to ensure proper assembly.

#### Step 1:

Place the table top (#1) onto a non-abrasive surface, such as a carpet, with its underside facing upwards. Fasten the legs (#2) to the underside of the table top (#1) rim by using bolts (#5). Keep the bolts loose. See Figure 1.



-  Use the correct bolts as indicated. Do not tighten any of the bolts until the table is completely assembled.
-  Do not sit or stand on this table.
-  Do not discard of any of the packaging until you have checked that you have all of the parts and fittings required.
-  Keep children away during assembly. This item contains small parts that can be swallowed by children. Children should always be under direct adult supervision while using this product.
-  Retain these assembly instructions for future reference.
-  Quote the following FQC NO. when contacting the service center.

SERVICE CENTER TOLL FREE NO.

TEL: 1-877-539-7436

FAX: 1-877-539-7439

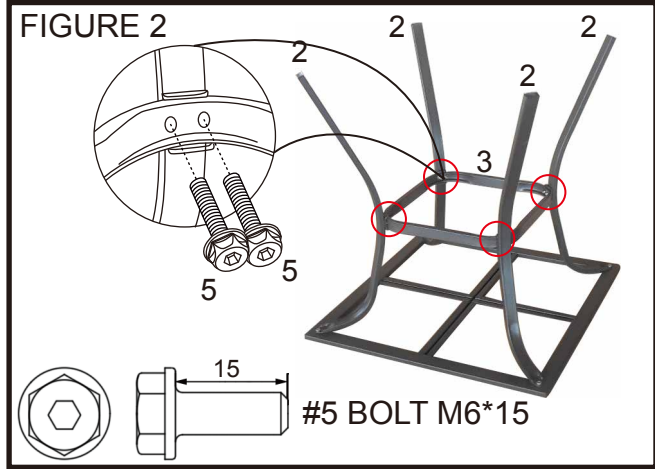

**Step 2:**  
Fasten the center connectors (#3) to the middle of the legs (#2) by using bolts (#5). Make sure that all of the bolts have been tightened completely . See Figure 2.

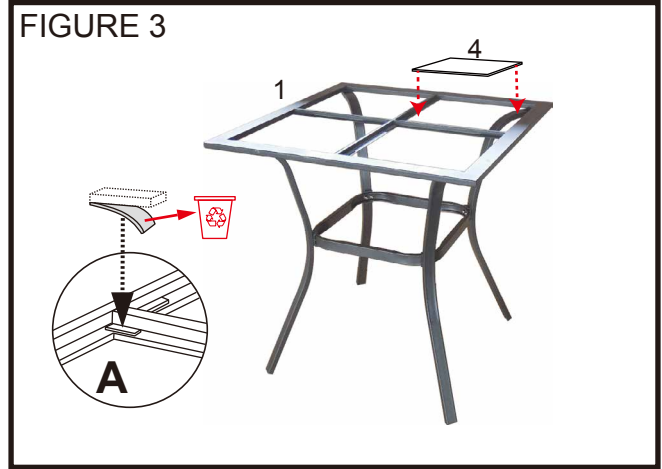

**Step 3:**  
Turn the table to its upright position. Place the tiles (#4) onto the table top (#1) carefully. See Figure 3 and Figure 4.

- Note:**
1. If any EVA foams on the table top (#1) are missing, there are extra EVA foams in the hardware kit. See Illustration A.
  2. To repair any scratches on the frame, use the touch-up paint (#11) provided.



**Cleaning and Maintenance**

- Wash frame parts with mild soap and water, rinse thoroughly, and dry completely. Do not use bleach, acid, or other solvents on the frame parts.
- Inspect and tighten all bolts and fasteners on a regular basis to ensure the proper performance and safety of your table.
- When moving the table, lift. Do not drag this table.
- We recommend the use of furniture covers when not in use.
- In order to prolong the life and beauty of your table, we recommend that it be stored in a dry and protected area during off season periods.

**Warranty**

- This product is covered by Courtyard Creations Inc. One–year limited warranty.
- Proof of purchase (dated register receipt) is required for warranty claims.
- It remains the customer’s responsibility for freight and packing charges to and from over service center.

**STOP!**  
**Missing A Part?**  
**No Need To Go Back To**  
**The Store**

The store where you made your purchase does not stock parts for this item. If you need parts, whether they are missing or damaged, Call Toll Free:

TEL: 1-877-539-7436  
 FAX: 1-877-539-7439  
 Call us between 9:00 AM and 4:30 PM Eastern Time Monday through Friday  
 For further assistance, please visit us at  
 service.cci@polywares.com

**READ THESE INSTRUCTIONS COMPLETELY BEFORE STARTING ASSEMBLY**

- ★ SEPARATE AND IDENTIFY ALL PARTS, MAKING SURE THAT YOU HAVE ALL OF THE PARTS LISTED.
- ★ IF YOU DO NOT LOCATE ALL OF THE PARTS LISTED, INSPECT THE PACKING MATERIAL FOR SMALL PARTS THAT MAY HAVE BECOME SEPARATED DURING SHIPMENT.
- ★ IF YOU EXPERIENCE ANY DIFFICULTY DURING ASSEMBLY OR IF ANY PARTS ARE MISSING OR DAMAGED, CALL THE HELP LINE AT 1-877-539-7436 BEFORE RETURNING THIS ITEM TO THE STORE.
- ★ PROVIDE THE FOLLOWING INFORMATION WHEN CALLING:  
 1-MODEL NUMBER OF THE PRODUCT.  
 2-PART NUMBER AND MATERIAL CODE OF THE PART FROM THE PARTS LIST.
- ★ MOST PROBLEMS CAN BE RESOLVED WITHOUT RETURNING THIS PRODUCT TO THE RETAILER.