













# ASSEMBLY INSTRUCTIONS

**ATTENTION: THIS PRODUCT IS NOT FOR COMMERCIAL USE  
INTENDED FOR RESIDENTIAL USE ONLY.**

## KTS8212

### PARTS LIST





PART NO.	MATERIAL CODE	PART	Q' TY
1	KTS8212-CS03-2	 BACK ASSEMBLY	1
2	KTS8212-CS02-1	 SEAT ASSEMBLY	1
3	KTS8211-CS01-2	 LEFT ARM	1
4	KTS8211-CS01-3	 RIGHT ARM	1
5	17C40A0705001YX	 BOLT M6*15	4
6	17C40A0716001YX	 BOLT M6*45	4

PART NO.	MATERIAL CODE	PART	Q' TY
7	17C40A0722001XY	 BOLT M6*65	1
8	17KAA0101----Y4	 HEX. KEY WRENCH 4MM	1
9	17KAC3101----Y3	 HEX. KEY WRENCH 10MM	1
10	61K8212X00001BA	 BACK CUSHION	2
11	61K8212Y00001BA	 LEFT SEAT CUSHION	1
12	61K8212Y50001BA	 RIGHT SEAT CUSHION	1

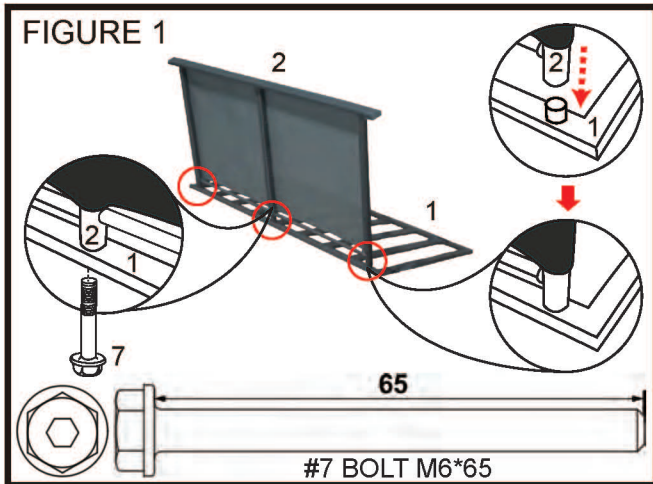
**Attention:**  
Make sure that each bolt needed for all steps matches the corresponding figure to ensure proper assembly.

**Step 1:**  
Place the back assembly (#1) onto a non-abrasive surface, such as a carpet. Insert the seat assembly (#2) into the back assembly (#1) and fasten seat assembly (#2) to the middle of back assembly (#1) by using bolts (#7). See Figure 1.



-  Use the correct bolts as indicated. Do not tighten any of the bolts until the chair is completely assembled.
-  Do not discard any of the packaging until you have checked that you have all of the parts and fittings required.
-  Keep children away during assembly. This item contains small parts that can be swallowed by children. Children should always be under direct adult supervision while using this product.
-  Retain these assembly instructions for future reference.
-  Quote the following FQC No. when contacting the service center.

SERVICE CENTER TOLL FREE NO.

TEL: 1-877-539-7436

FAX: 1-877-539-7439

FIGURE 2

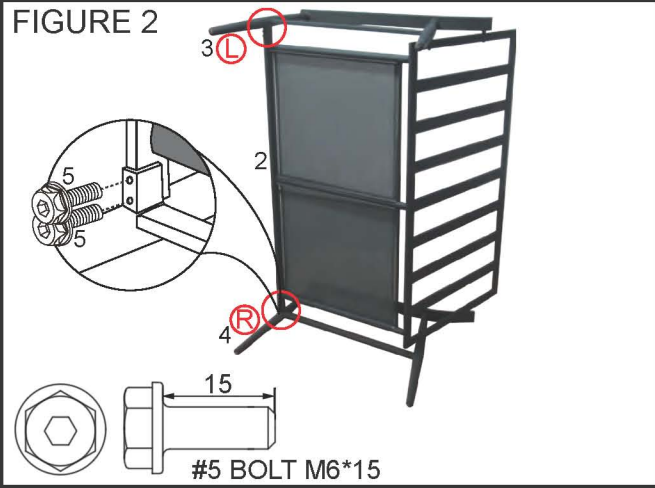

Step 2:  
At the front of the seat, fasten the arms (#3 and #4) to the seat assembly (#2) by using bolts (#5). Keep the bolts loose. See Figure 2.

**Note:**  
The labels marked "L" and "R" on arms (#3 and #4) should coincide with Figure 2 to ensure proper assembly.

FIGURE 3

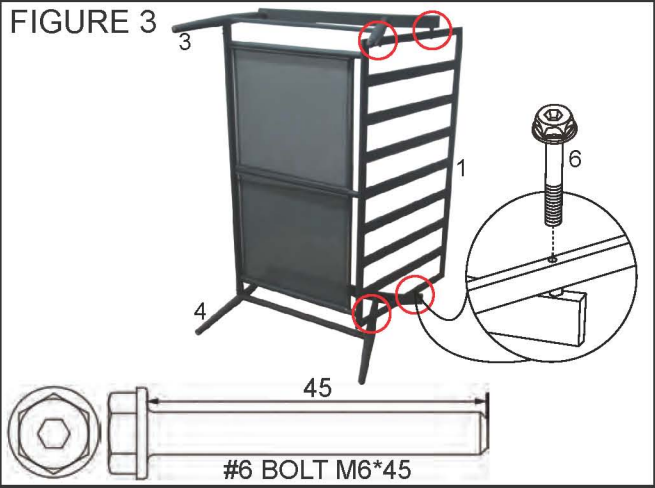

Step 3:  
Fasten both the left arm (#3) and the right arm (#4) to the back assembly (#1) by using bolts (#6). Make sure that all of the bolts have been tightened completely. See Figure 3.

FIGURE 4

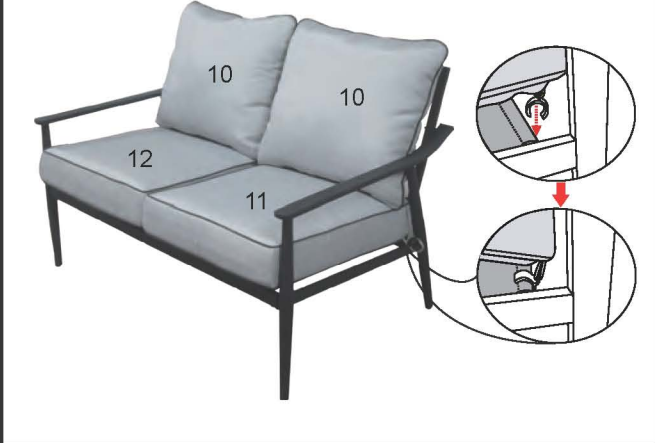

Step 4:  
Place the cushions (#10, #11 and #12) onto the chair. Secure the cushions to the chair by using the plastic clamps. See Figure 4.

Cleaning and Maintenance

- Wash frame and fabric parts with mild soap and water, rinse thoroughly, and dry completely. Do not use bleach, acid, or other solvents on the frame or fabric parts.
- The cushions may be washed on the surface only by using mild soap and water or a commercial foaming upholstery cleaner if necessary. If washed, rinse well and hang to dry. Do not machine wash or dry.
- We recommend the use of furniture covers when not in use.
- Inspect and tighten all bolts and fasteners on a regular basis to ensure the proper performance and safety of your chair.
- In order to prolong the life and beauty of your chair, we recommend that it be stored in a dry and protected area during off season periods.

Warranty

- This product is covered by Courtyard Creations Inc.'s one-year limited warranty.
- Proof of purchase (dated register receipt) is required for warranty claims.
- It remains the customer's responsibility for freight and packing charges to and from the service center.

**STOP!**  
Missing A Part?  
No Need To Go Back To  
The Store

The store where you made your purchase does not stock parts for this item. If you need parts, whether they are missing or damaged, Call Toll Free:

TEL: 1-877-539-7436  
FAX: 1-877-539-7439  
Call us between 9:00 AM and 4:30 PM Eastern Time Monday through Friday

For further assistance, please visit us at [service.cci@polywares.com](mailto:service.cci@polywares.com)

READ THESE INSTRUCTIONS COMPLETELY BEFORE STARTING ASSEMBLY

- ★ SEPARATE AND IDENTIFY ALL OF THE PARTS, MAKING SURE THAT YOU HAVE ALL OF THE PARTS LISTED.
- ★ IF YOU DO NOT LOCATE ALL OF THE PARTS LISTED, INSPECT THE PACKING MATERIAL FOR SMALL PARTS THAT MAY HAVE BECOME SEPARATED DURING SHIPMENT.
- ★ IF YOU EXPERIENCE ANY DIFFICULTY DURING ASSEMBLY OR IF ANY PARTS ARE MISSING OR DAMAGED, CALL THE HELP LINE AT 1-877-539-7436 BEFORE RETURNING THIS ITEM TO THE STORE.
- ★ PROVIDE THE FOLLOWING INFORMATION WHEN CALLING:  
1-MODEL NUMBER OF THE PRODUCT.  
2-PART NUMBER AND MATERIAL CODE OF THE PART FROM THE PARTS LIST.
- ★ MOST PROBLEMS CAN BE RESOLVED WITHOUT RETURNING THIS PRODUCT TO THE RETAILER.