









ASSEMBLY INSTRUCTIONS





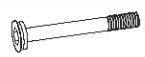

**ATTENTION: THIS PRODUCT IS NOT FOR COMMERCIAL USE
INTENDED FOR RESIDENTIAL USE ONLY.**

PARTS LIST

TGS55HK

AT4040-92

PART NO.	MATERIAL CODE	PART	Q'TY
1	AT4040-92-01	 TABLE TOP	1
2	AT4040-92-02	 LEG	4
3	AT4040-92-03	 SUPPORTS	2
4	AT4040-92-04	 CENTER CONNECTOR	1
5	AT4040-92-05	 LEG CONNECTORS	4
A	AT4040-92-06	 ST4.2 x 12 screws	6
B	AT4040-92-07	 M6 x 59mm bolts	4
C	AT4040-92-08	 M6 x 35mm bolts	4

PART NO.	MATERIAL CODE	PART	Q'TY
D	AT4040-92-09	 M6 x 50mm bolts	2
E	AT4040-92-10	 D13 washers	20
F	AT4040-92-11	 M6 metal nuts	10
G	AT4040-92-12	 M6 x P1.0 plastic nuts	10
H	AT4040-92-13	 M6 bolt caps	10
I	AT4040-92-14	 10mm nut wrench	1
J	AT4040-92-15	 4mm hex key	1

You will need the following tools:

- Phillips Screwdriver (Not Included) 





- Hex. Key Wrench (See Part #J) 

- Nut Wrench (See Part #I) 

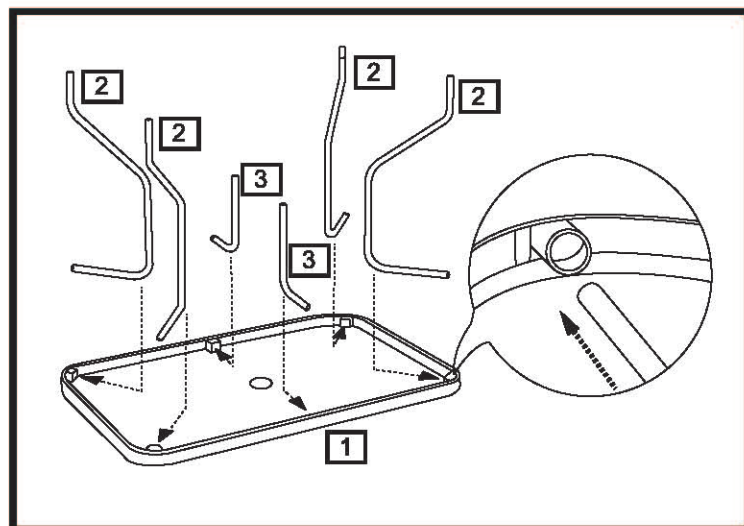
Step 1

Place the table top **1** onto a non-abrasive surface, such as a carpet, with its underside facing upwards. Insert the legs **2** and the supports **3** into the plastic holders on the underside of the table top **1** rim.



-  Use the correct bolts as indicated. Do not tighten any of the bolts until the table is completely assembled.
-  Do not sit or stand on this table.
-  Do not discard any of the packaging until you have checked that you have all of the parts and fittings required.
-  Keep children away during assembly. This item contains small parts that can be swallowed by children. Children should always be under direct adult supervision while using this product.
-  Retain these assembly instructions for future reference.

SERVICE CENTER TOLL FREE NO.

TEL: 1-877-539-7436

FAX: 1-877-539-7439

PAGE 1 OF 3

COURTYARD CREATIONS INC.

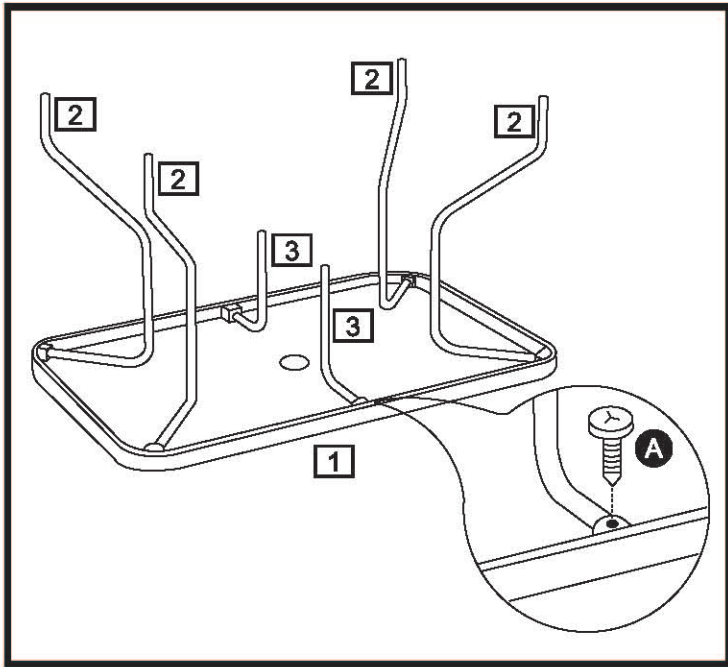

Step 2

Attach the supports **3** and legs **2** to the plastic holders on the underside of the table top **1** rim by using screws **A**.

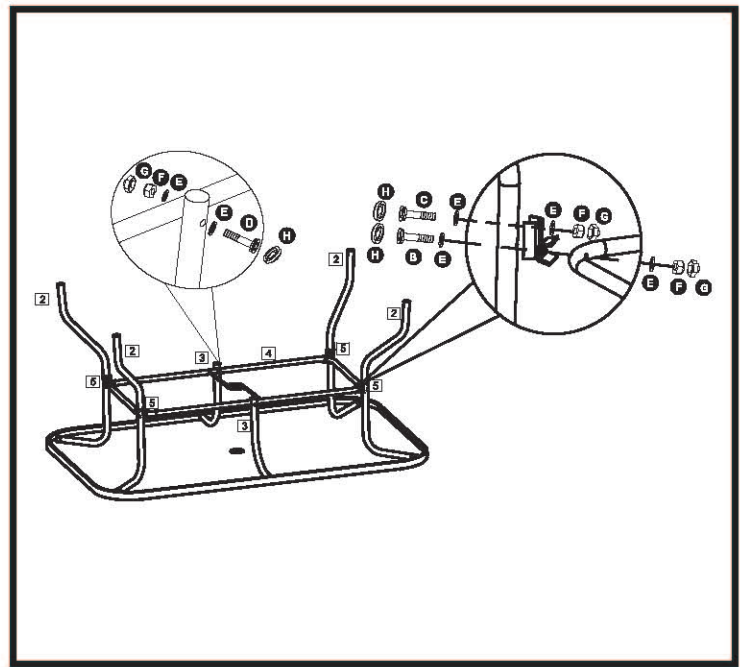

Step 3

Fix the centre connector with ring **4** and the leg connector **5** to the middle of the legs **2** by using bolts **B** and **C**, washers **E**, metal nut **F** and plastic nuts **G**. Fix the centre connector with ring **4** to the supports **3** by using bolts **D**, washers **E**, metal nut **F** and plastic nuts **G**. Make sure that all of the bolts have been tightened completely and cover them with bolt caps **H**.

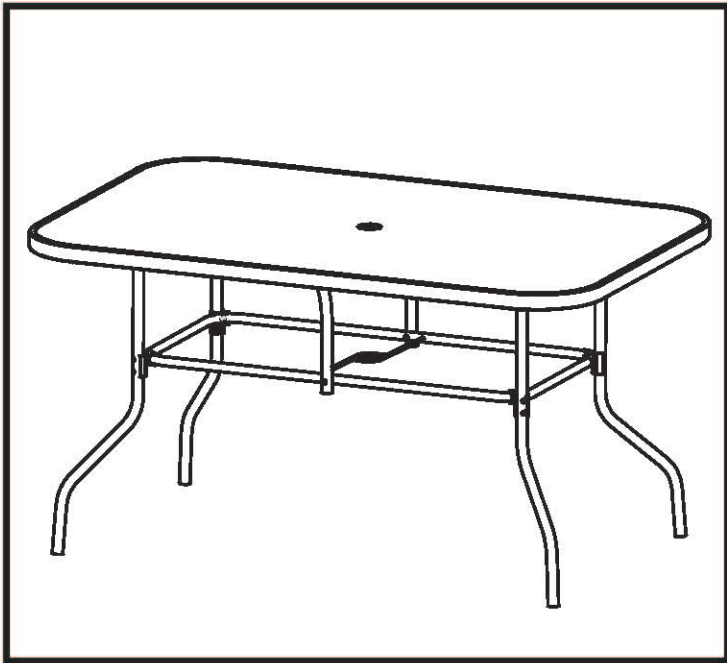

Step 4

Turn the table to its upright position.

Cleaning and Maintenance

- Wash frame parts with mild soap and water, rinse thoroughly, and dry completely. Do not use bleach, acid, or other solvents on the frame parts.
- Wash glass with mild soap and water, rinse thoroughly, and dry completely.
- Inspect and tighten all bolts and fasteners on a regular basis to ensure the proper performance and safety of your table.
- When moving the table, lift. Do not drag this table.
- We recommend the use of furniture covers when not in use.
- In order to prolong the life and beauty of your table, we recommend that it be stored in a dry and protected area during off season periods.

Warranty

- This product is covered by Courtyard Creations Inc. One-year limited warranty.
- Proof of purchase (dated register receipt) is required for warranty claims.
- It remains the customer's responsibility for freight and packing charges to and from over service center.



READ THESE INSTRUCTIONS COMPLETELY BEFORE STARTING ASSEMBLY

- ★ SEPARATE AND IDENTIFY ALL PARTS, MAKING SURE THAT YOU HAVE ALL OF THE PARTS LISTED.
- ★ IF YOU DO NOT LOCATE ALL OF THE PARTS LISTED, INSPECT THE PACKING MATERIAL FOR SMALL PARTS THAT MAY HAVE BECOME SEPARATED DURING SHIPMENT.
- ★ IF YOU EXPERIENCE ANY DIFFICULTY DURING ASSEMBLY OR IF ANY PARTS ARE MISSING OR DAMAGED, CALL THE HELP LINE AT 1-877-539-7436 BEFORE RETURNING THIS ITEM TO THE STORE.
- ★ PROVIDE THE FOLLOWING INFORMATION WHEN CALLING:
1-MODEL NUMBER OF THE PRODUCT.
2-PART NUMBER AND MATERIAL CODE OF THE PART FROM THE PARTS LIST.
- ★ MOST PROBLEMS CAN BE RESOLVED WITHOUT RETURNING THIS PRODUCT TO THE RETAILER.