



# ASSEMBLY INSTRUCTIONS

ATTENTION: THIS PRODUCT IS NOT FOR COMMERCIAL USE  
INTENDED FOR RESIDENTIAL USE ONLY.

## KUS605P

### PARTS LIST

PART NO.	MATERIAL CODE	PART	Q'TY
1	KUS605P-CS11-1	 SEAT ASSEMBLY	1
2	KUS605P-CS04-1	 BASE ASSEMBLY	1
3	17C40A0712001YX	 BOLT M6*35	4



4	1808010345701	 PLASTIC CAP	2
5	17KAA0101----Y4	 HEX. KEY WRENCH 4MM	1
6	61K605PX00001BA	 BACK CUSHION	1
7	61K605PY00001BA	 SEAT CUSHION	1

FIGURE 1





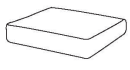
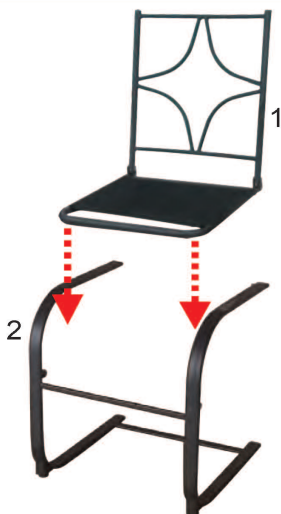
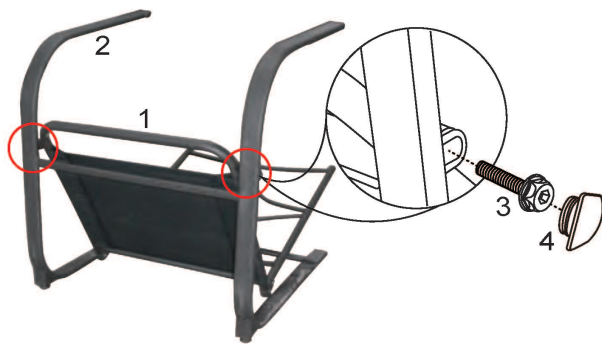

Step 1:  
Properly position the seat assembly (#1) to the base assembly (#2). See Figure 1.

FIGURE 2



Step 2:  
At the front of the chair, fasten the seat assembly (#1) to the base assembly (#2) by using bolts (#3). Keep the bolts loose. See Figure 2.

-  Use the correct bolts as indicated. Do not tighten any of the bolts until the chair is completely assembled.
-  Do not discard any of the packaging until you have checked that you have all of the parts and fittings required.
-  Keep children away during assembly. This item contains small parts that can be swallowed by children. Children should always be under direct adult supervision while using this product.
-  Retain these assembly instructions for future reference.
-  Quote the following FQC No. when contacting the service center.

SERVICE CENTER TOLL FREE NO.  
TEL: 1-877-539-7436  
FAX: 1-877-539-7439

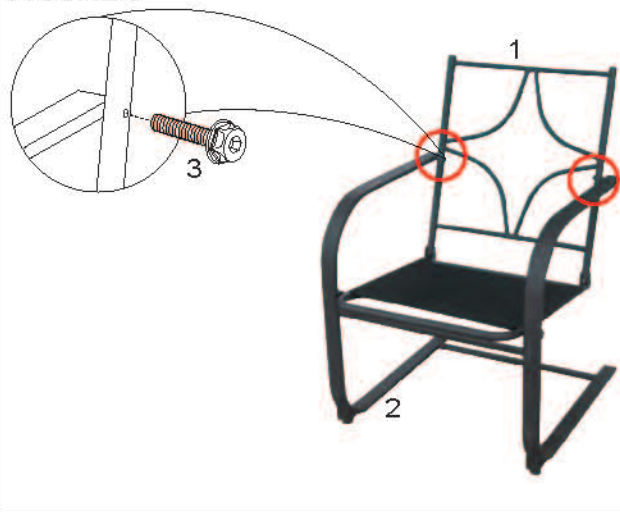

**FIGURE 3**

**Step 3:**  
 At the back of the chair, fasten the seat assembly (#1) to the base assembly (#2) by using bolts (#3). Make sure that all of the bolts have been tightened completely and cover them with plastic caps (#4). See Figure 3.

**FIGURE 4**

**Step 4:**  
 Place the cushions (#6 and #7) onto the chair. Secure the cushion to the chair by using the plastic clamps. You can adjust the leveler on base assembly (#2) to keep the chair even when it is not stable. See Figure 4.

### Cleaning and Maintenance

- Wash frame parts with mild soap and water, rinse thoroughly, and dry completely. Do not use bleach, acid, or other solvents on the frame parts.
- The cushion may be washed on the surface only by using mild soap and water or a commercial foaming upholstery cleaner if necessary. If washed, rinse well and hang to dry. Do not machine wash or dry.
- We recommend the use of furniture covers when not in use.
- Inspect and tighten all bolts and fasteners on a regular basis to ensure proper performance and safety of your chair.
- In order to prolong the life and beauty of your chair, we recommend that it be stored in a dry and protected area during off season periods.

### Warranty

- This product is covered by Courtyard Creations Inc. one-year limited warranty.
- Proof of purchase (dated register receipt) is required for warranty claims.
- It remains the customer's responsibility for freight and packing charges to and from the service center.

# STOP!

**Missing A Part?  
 No Need To Go Back To  
 The Store**

The store where you made your purchase does not stock parts for this item.

If you need parts, whether they are missing or damaged, Call Toll Free:

TEL: 1-877-539-7436

FAX: 1-877-539-7439

Call us between 9:00 AM and 4:30 PM Eastern Time Monday through Friday

For further assistance,

please visit us at

service.cci@polywares.com

### **READ THESE INSTRUCTIONS COMPLETELY BEFORE STARTING ASSEMBLY**

- ★ **SEPARATE AND IDENTIFY ALL OF THE PARTS, MAKING SURE THAT YOU HAVE ALL OF THE PARTS LISTED.**
- ★ **IF YOU DO NOT LOCATE ALL OF THE PARTS LISTED, INSPECT THE PACKING MATERIAL FOR SMALL PARTS THAT MAY HAVE BECOME SEPARATED DURING SHIPMENT.**
- ★ **IF YOU EXPERIENCE ANY DIFFICULTY DURING ASSEMBLY OR IF ANY PARTS ARE MISSING OR DAMAGED, CALL THE HELP LINE AT 1-877-539-7436 BEFORE RETURNING THIS ITEM TO THE STORE.**
- ★ **PROVIDE THE FOLLOWING INFORMATION WHEN CALLING:  
 1-MODEL NUMBER OF THE PRODUCT.  
 2-PART NUMBER AND MATERIAL CODE OF THE PART FROM THE PARTS LIST.**
- ★ **MOST PROBLEMS CAN BE RESOLVED WITHOUT RETURNING THIS PRODUCT TO THE RETAILER.**