













ASSEMBLY INSTRUCTIONS

**ATTENTION: THIS PRODUCT IS NOT FOR COMMERCIAL USE
INTENDED FOR RESIDENTIAL USE ONLY.**

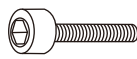
RTS0221

PARTS LIST

| PART NO. | MATERIAL CODE | PART | Q'TY | | | | |
|----------|-----------------|--|------|----|-----------------|---|---|
| 1 | RTS0221-CS11-2 | SEAT ASSEMBLY  | 1 | 7 | 17FA08060601-YX |  | 4 |
| 2 | RTS0221-CS12-1 | BASE ASSEMBLY  | 1 | 8 | 17FC08030801-YX |  | 4 |
| 3 | RFS8821-CS04 | SEAT POST  | 1 | 9 | 17FA05100701-YX |  | 1 |
| 4 | 18000744004 | DECORATIVE PLASTIC COVER  | 1 | 10 | 17D03A040401-YX |  | 4 |
| 5 | 17C03A0814041YX | BOLT M8*40  | 4 | 11 | 17KAA0101----Y4 |  | 1 |
| 6 | 17C40A0712001YX | BOLT M6*35  | 1 | 12 | 17KAA0201----Y4 |  | 1 |
| | | | | 13 | 17KAB1101----Y4 |  | 1 |





Attention:

Make sure that each bolt needed for all steps matches the corresponding figure to ensure proper assembly.

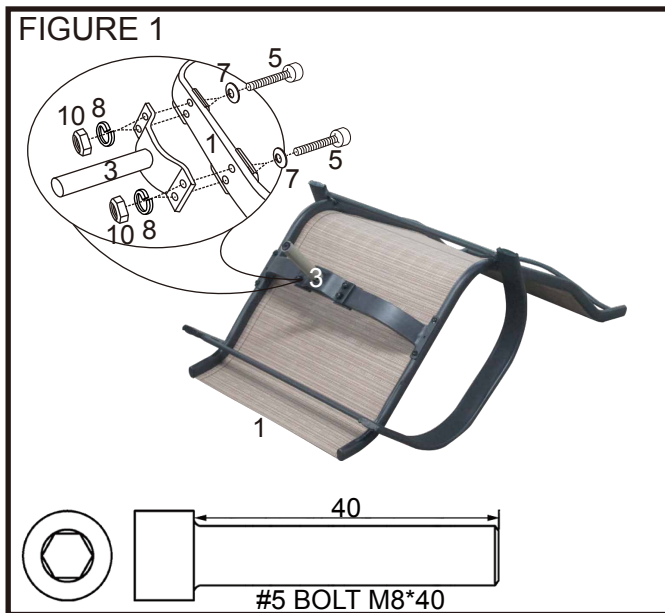
Step 1:

Place the seat assembly (#1) onto a non-abrasive surface, such as a carpet. Fasten the seat post (#3) to the seat assembly (#1) by using bolts (#5), washers (#7 and #8), and jam nuts (#10). See Figure 1.



-  Use the correct bolts as indicated. Do not tighten any of the bolts until the swivel chair is completely assembled.
-  Do not discard any of the packaging until you have checked that you have all of the parts and fittings required.
-  Keep children away during assembly. This item contains small parts that can be swallowed by children. Children should always be under direct adult supervision while using this product.
-  Retain these assembly instructions for future reference.
-  Quote the following FQC NO. when contacting the service center.

SERVICE CENTER TOLL FREE NO.
TEL: 1-877-539-7436
FAX: 1-877-539-7439

FIGURE 2

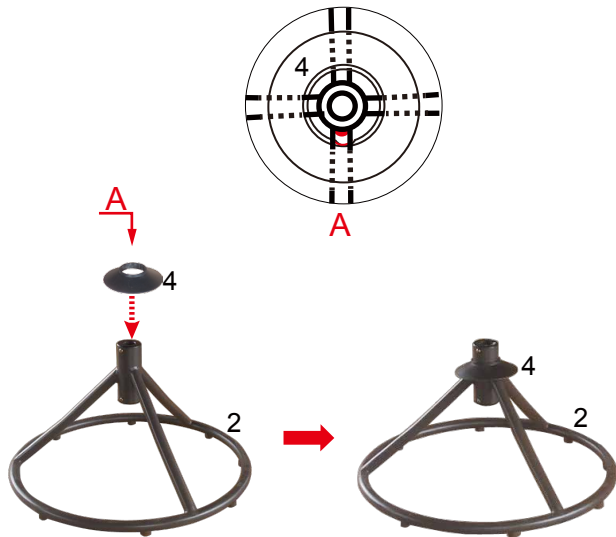

Step 2:
Place the decorative plastic cover (#4) on the chair's base assembly (#2) as illustrated above. See Figure 2.

FIGURE 3

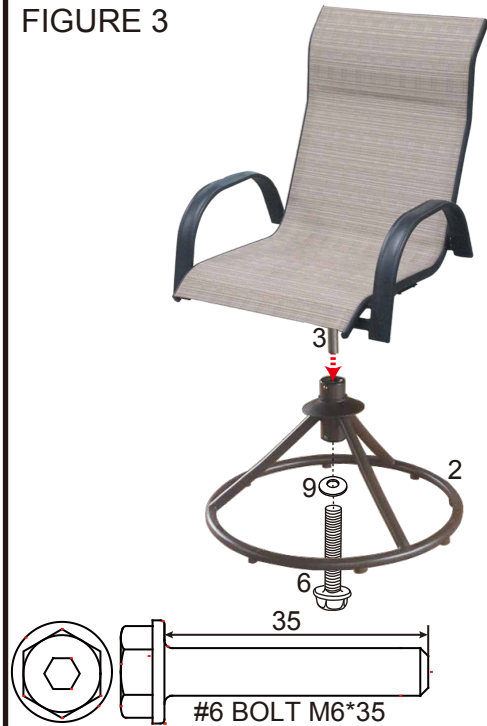

Step 3:
Insert the seat post (#3) into the hole in the center of the base assembly (#2). Fasten them together by using bolt (#6) and washer (#9). Make sure that all of the bolts have been tightened completely. See Figure 3 and Figure 4.

Note:

For ease with installation, we recommend that the seat post (#3) be slightly oiled or waxed before fastening it to the base assembly (#2).

Caution:

To ensure one's safety during use of this swivel chair, make sure that all of the bolts are completely tightened. This chair has the ability to swivel; therefore, use by young children should be adult supervised.

Cleaning and Maintenance

- Wash frame and fabric parts with mild soap and water, rinse thoroughly, and dry completely. Do not use bleach, acid, or other solvents on the frame or fabric parts.
- We recommend the use of furniture covers when not in use.
- Inspect and tighten all bolts and fasteners on a regular basis to ensure the proper performance and safety of your swivel chair.
- In order to prolong the life and beauty of your swivel chair, we recommend that it be stored in a dry and protected area during off season periods.

FIGURE 4



Warranty

- This product is covered by Courtyard Creations Inc.'s one-year limited warranty.
- Proof of purchase (dated register receipt) is required for warranty claims.
- It remains the customer's responsibility for freight and packing charges to and from the service center.

STOP!
Missing A Part?
No Need To Go Back To
The Store

The store where you made your purchase does not stock parts for this item.
If you need parts, whether they are missing or damaged, Call Toll Free:
TEL: 1-877-539-7436
FAX: 1-877-539-7439
Call us between 9:00 AM and 4:30 PM Eastern Time Monday through Friday
For further assistance, please visit us at service.cc@polywares.com

READ THESE INSTRUCTIONS COMPLETELY BEFORE STARTING ASSEMBLY

- ★ SEPARATE AND IDENTIFY ALL OF THE PARTS, MAKING SURE THAT YOU HAVE ALL OF THE PARTS LISTED.
- ★ IF YOU DO NOT LOCATE ALL OF THE PARTS LISTED, INSPECT THE PACKING MATERIAL FOR SMALL PARTS THAT MAY HAVE BECOME SEPARATED DURING SHIPMENT.
- ★ IF YOU EXPERIENCE ANY DIFFICULTY DURING ASSEMBLY OR IF ANY PARTS ARE MISSING OR DAMAGED, CALL THE HELP LINE AT 1-877-539-7436 BEFORE RETURNING THIS ITEM TO THE STORE.
- ★ PROVIDE THE FOLLOWING INFORMATION WHEN CALLING:
1-MODEL NUMBER OF THE PRODUCT.
2-PART NUMBER AND MATERIAL CODE OF THE PART FROM THE PARTS LIST.
- ★ MOST PROBLEMS CAN BE RESOLVED WITHOUT RETURNING THIS PRODUCT TO THE RETAILER.