

IMPORTANT!! PLEASE READ ENTIRE INSTRUCTION SHEET BEFORE ASSEMBLY!!
TO EXPEDITE ANY FUTURE WARRANTY CLAIMS, PLEASE KEEP INSTRUCTION SHEET, WARRANTY CARD AND RECEIPT

IMPORTANT NOTE: Your seat may appear to be slightly warped. This is not unusual. Proper assembly procedure will straighten out the seat in the frame. There are four bolts used to attach the seat frame to the chair base. After inserting all the bolts, each of these bolts must be tightened a few revolutions at a time in rotation.

Step 1: Identify all parts packed in the carton against the parts list. Remove all protective materials. Set parts on a flat, non-abrasive surface to avoid scratching.

IMPORTANT NOTE: Assembling this chair requires attaching the sling seat frame to the chair base. We recommend two people work together to assemble the chair since it is critical that all the holes in the seat frame are aligned exactly with the holes in the seat base. All bolts need to be inserted and tightened into the fixed nuts in a straight and direct path. Inserting the bolts at even the slightest angle could strip the nuts and bolts, damaging the entire chair.

Step 2: Working from behind the chair, have another person stand in front of the chair and position the sling seat frame in between the arms of the chair base as shown **Fig.1** so that the holes on both sides of the upper portion of the seat frame back align with the fixed nut holes in the chair base.

Step 3: Working from the underside of the front of the chair, insert a 5/16"x22 mm bolt with a washer through the seat frame and into the fixed nut holes in the chair base as shown in **Fig.2**. **Hand tighten 3-4 revolutions only. DO NOT TIGHTEN COMPLETELY.** Repeat for the opposite side.







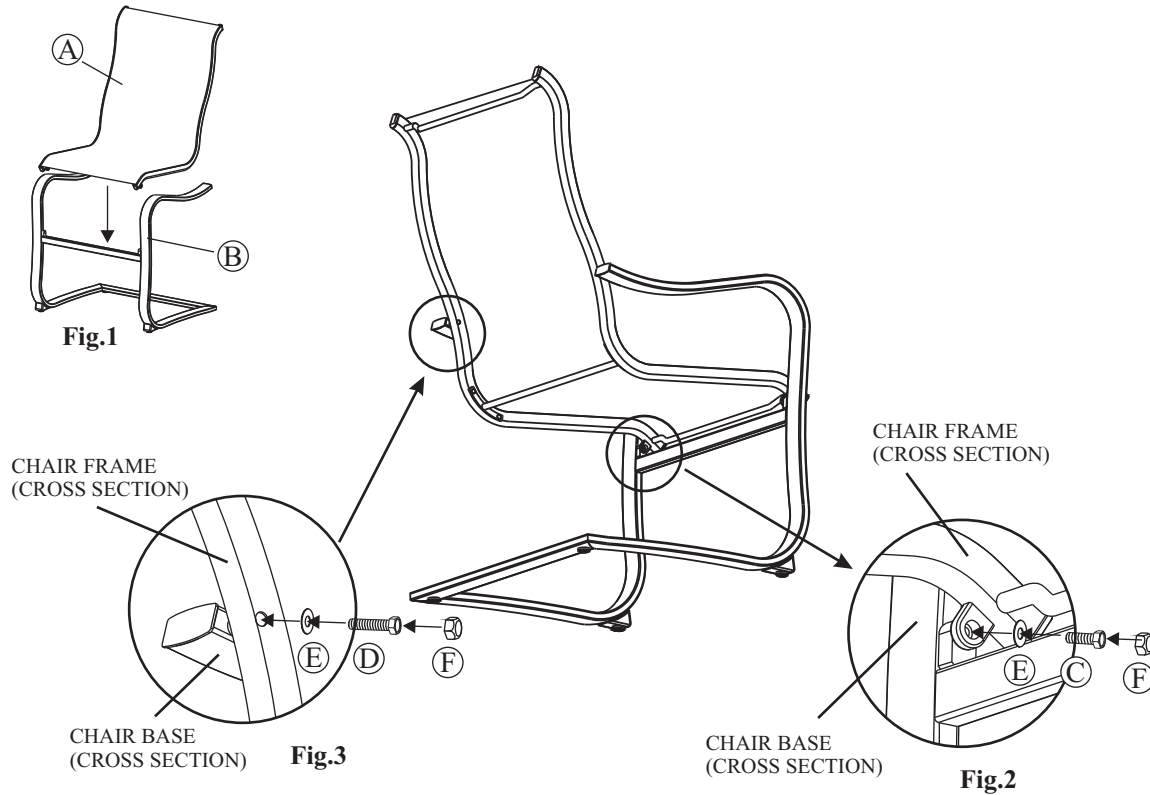

Step 4: From behind the chair, insert a 5/16"x35 bolt with a washer through the hole on one side of back of the seat frame and into the fixed nut hole in the back arm of the chair base as shown in **Fig.3**. Make sure the bolt is inserted exactly straight! **Hand tighten 3-4 revolutions only. DO NOT TIGHTEN COMPLETELY.** Repeat for the opposite side of the chair.

Step 5: Tighten all bolts. Each bolt must be tightened a 3-4 revolutions only at a time. Begin with top left bolt. Move to bottom right bolt then to top right bolt, followed by bottom left bolt. Repeat this "X" pattern until all bolts are tight. **DO NOT OVER TIGHTEN BOLTS.** Over tightening may strip bolts or nuts, damaging the entire chair. Cover all bolts with bolt covers.

Step 6: Examine the chair from the front. If the sling seat does not appear tight or straight in the chair base, repeat steps 3, 4 and 5.



* NOTE: PARTS SHOWN ON PARTS LIST ARE NOT TO SCALE

	PARTS LIST	DESCRIPTION	ORDER PART #	QTY		PARTS LIST	DESCRIPTION	ORDER PART #	QTY
A		SEAT FRAME	AN0761	1	H		HEX WRENCH	HW0008	1
B		CHAIR BASE	AN0762	1			SLING TUBE CAP FACTORY ASSEMBLY	FC0427	
C		5/16" X 22 MM BOLT	HW0507	2			FOOT CAP FACTORY ASSEMBLY	FC0010	
D		5/16" X 35 MM BOLT	HW0066	2					
E		Ø8.5 X 1.5 MM WASHER	HW0861	4					
F		BOLT COVER	HW0028	4					

ADE03919

CARE AND MAINTENANCE

FRAMES

Cleaning - Use mild soap and warm water. Do not use abrasive materials, cleansers or bleach products. Rinse with clean water and dry thoroughly.

Maintenance - Periodically clean and dry thoroughly. Be sure to drain any water accumulated inside the frames. To thoroughly drain frames, remove foot caps and tilt the frames, if necessary, to remove all water. This is critical. Water allowed to accumulate inside the frames and then exposed to sub-freezing temperatures can cause damage to the frame tubing. Such damage is not covered under warranty. Always clean, drain and dry thoroughly before storing for the winter. For best results, always store or cover your furniture when not in use. We recommend commercially available outdoor furniture covers. Any small nicks or scratches can be covered with a light application of touch-up paint.

** When cleaning or moving large or heavy items, always have two people work together. Never drag furniture.

FABRICS (CUSHIONS/SLINGS)

Cleaning - Wipe minor spills immediately. Clean with mild soap, warm clean water and soft cloth. Do not use abrasive materials, cleansers or bleach products. Although fabric has been treated to resist stains, occasional use of commercially available fabric cleaners may be necessary. Follow manufacturer's instructions.

Maintenance - The best way to maintain the beauty of cushions and slings is to store them in a dry area and out of the elements when not in use or cover with commercially available outdoor furniture covers.

STRAPS

Cleaning - Wash frequently with mild soap, warm water and a soft cloth. Rinse thoroughly with warm, clean water. Do not use abrasive materials, cleansers or bleach products.

Maintenance - Periodic application of commercially available vinyl cleaners and vinyl protectors will enhance the look and prolong the life of straps. If your strap chair has cushions, make sure any vinyl protectors applied are completely dry before placing cushion back on the chair.

LIMITED WARRANTY

- **Frames.** Frame construction is warranted against defects in material and workmanship for seven years from purchase date. Damage to frames or welds resulting from improper assembly or exposure to water and/or sub-freezing temperatures is not covered.
- **Finishes.** Paint finishes are warranted against peeling, cracking, and blistering for one year from purchase date provided the unit has not been scratched or abraded. Chips and scratches resulting from normal wear and tear are not covered.
- **Fabrics.** Fabric and cushions (if applicable) are warranted against separation at the seams for one year from purchase date. Fading and/or discoloration resulting from exposure to the elements, oils, spills, fluids, chemicals, or any other cause is not covered.
- **Straps and/or wicker.** Straps and/or wicker weave (if applicable) are warranted against separation and tearing for one year from purchase date. Fading and/or discoloration resulting from exposure to the elements, oils, spills, fluids, chemicals, or any other cause is not covered.
- **Umbrellas.** Umbrellas (if applicable) are warranted against defects in material and workmanship only for one year from purchase date. Umbrella bases (if applicable) are not covered under any circumstance.
- **Table tops.** Natural stone tabletops only are warranted against defects in materials or workmanship only for one year from purchase date. All other table tops (including without limitation glass and faux stone) are not covered under any circumstances.

Warranty limitations: This warranty is subject to the limitations set forth above. In addition, this warranty is made to the original purchaser only, and is effective only when item(s) is purchased from one of our authorized dealers. This warranty is not transferable. For warranty replacements based on warranty claims submitted within the first year of purchase, we will pay shipping and handling charges within the continental North America. After the first year, shipping and handling charges are your responsibility. We will not be responsible for charges associated with shipments outside the continental North America at any time or for any reason.

Warranty exclusions: This warranty is subject to the exclusions as set forth above. In addition, the following are excluded from coverage under this warranty: any item used for commercial, contract or any other non-residential purpose; clearance items, display models or items purchased "as is"; freight damage; items subject to misuse, abuse, neglect or lack of proper care and maintenance (including without limitation as provided in any "care and maintenance guide"); normal wear and tear; damage caused by acts of nature, acts of force majeure, vandalism, fire or other casualty, or improper assembly; hardware against corrosion or rusting; purchased or replacement parts; and all plastic parts. Also excluded are loss of use or time; inconvenience; money; travel; packaging; or incidental, special or consequential damages of any kind. Replacement of defective items as provided herein shall constitute your sole and exclusive remedy for items which are not as warranted. In no event shall our responsibility exceed the purchase price of the items found to be other than as warranted. This warranty is the exclusive statement of your rights with respect to the defects in the items you have purchased and supersedes any other express warranty or statement, written or oral, made in connection with the purchase and sale of such items. When used herein, the term "item" when used in the singular, refers to the specific item found to be defective, and not to the entire set of which the item is a part.

Some states do not allow exclusion or limitation of incidental or consequential damages, so that limitation above may not apply to you. This warranty gives you specific legal rights, and you may also have other rights which vary from state to state.

PATIO FURNITURE & ACCESSORIES ASSEMBLY INSTRUCTIONS

IMPORTANT!!!

STOP! PLEASE READ THESE INSTRUCTIONS CAREFULLY BEFORE ASSEMBLY. MAKE SURE YOU HAVE ALL THE PARTS AND HARDWARE AS IDENTIFIED ON THE PARTS LIST.