

**IMPORTANT!! PLEASE READ ENTIRE INSTRUCTION SHEET BEFORE ASSEMBLY!!  
TO EXPEDITE ANY FUTURE WARRANTY CLAIMS, PLEASE KEEP INSTRUCTION SHEET, WARRANTY CARD AND RECEIPT**

**Step 1:** Remove all protective materials and set parts on a flat, non-abrasive surface. Identify parts packed in the carton against the parts list.

**Step 2:** Attach a leg to the leg connector bracket by carefully guiding the bolts already in place on the table legs (each leg has two bolts) through the holes in the leg connector bracket. Add a washer and a nut to the end of each bolt as shown in **Figure 1**. **Hand tighten 2-3 turns only.** Repeat on the other three legs.

**Step 3:** Place the table top upside down on a flat, non-abrasive surface. Attach a leg to the table top by using two bolts and washers as shown in **Figure 2**. **Hand tighten only 2-3 turns.** Repeat for the other three legs.

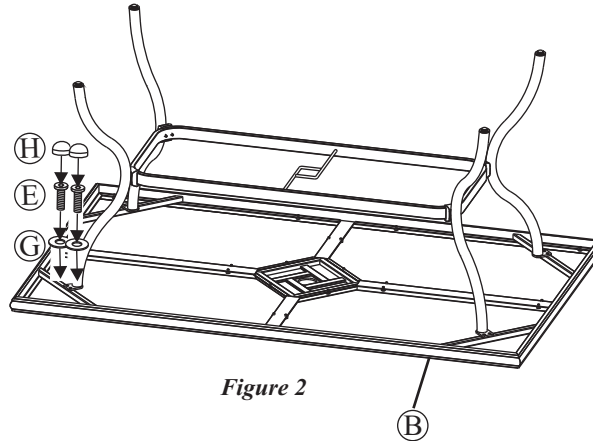

*Figure 2*

**Step 4:** After making any necessary adjustments to the alignment of the table base and table top, use the hex bolt driver to tighten all bolts. **Note:** each bolt must be tightened a few revolutions at a time. In order to apply equal pressure to all bolt joints, we recommend working in a cross corner (X fashion). Repeat until all bolts are tight. **Do not over tighten.** Over tightening may strip bolts. Cover all bolts with covers.

**Step 5:** With the help of another person, turn the table in the upright position. Note the table bumpers spaced evenly throughout the inside of the table rim. Carefully place tiles inside the rim, resting on the clear bumpers. Your table is now ready for use.

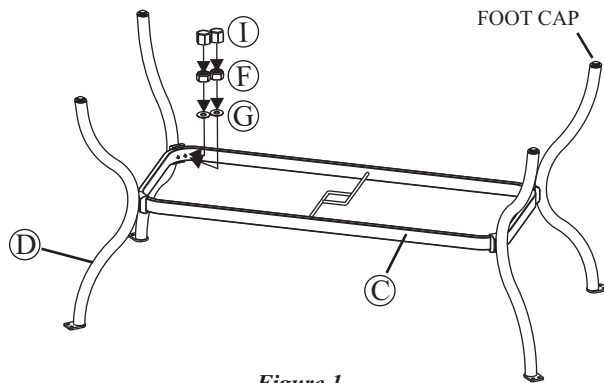

*Figure 1*

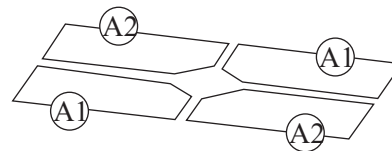

*\* NOTE: PARTS SHOWN ON PARTS LIST ARE NOT TO SCALE*

	<u>PARTS LIST</u>	<u>DESCRIPTION</u>	<u>ORDER PART #</u>	<u>QTY</u>
A1		TILE 1	FP2376	2
A2		TILE 2	FP2377	2
B		TABLE RIM	FP2378	1
C		LEG CONNECTOR BRACKET	FP2379	1
D		TABLE LEG	FP2380	4
E		1/4" X 20 MM BOLT	HW0036	8
F		1/4" NUT	HW0014	8
G		Ø6.5 X 1.0 MM WASHER	HW0004	16
H		BOLT COVER-1	HW0105	8
I		BOLT COVER-2	HW0027	8
J		HEX BOLT DRIVER	HW0006	1
K		HEX WRENCH	HW0009	1
		TABLE BUMPER <i>FACTORY ASSEMBLY</i>	G0217	
		UMBRELLA HOLE RING (SET) <i>FACTORY ASSEMBLY</i>	G0235 & G0236	
		FOOT CAP <i>FACTORY ASSEMBLY</i>	FC0612	

ALE19317

## CARE AND MAINTENANCE

### **FRAMES**

*Cleaning* - Use mild soap and warm water. Do not use abrasive materials, cleansers or bleach products. Rinse with clean water and dry thoroughly.

*Maintenance* - Periodically clean and dry thoroughly. Be sure to drain any water accumulated inside the frames. To thoroughly drain frames, remove foot caps and tilt the frames, if necessary, to remove all water. This is critical. Water allowed to accumulate inside the frames and then exposed to sub-freezing temperatures can cause damage to the frame tubing. Such damage is not covered under warranty. Always clean, drain and dry thoroughly before storing for the winter. For best results, always store or cover your furniture when not in use. We recommend commercially available outdoor furniture covers. Any small nicks or scratches can be covered with a light application of touch-up paint.

\*\* When cleaning or moving large or heavy items, always have two people work together. Never drag furniture.

### **CERAMIC TILE**

Use clean water and mild detergent or commercially available ceramic tile cleaners as necessary. Do not use abrasive materials or cleansers as they may scratch the surface of the tiles. Dry with soft cloth. We do not recommend repeated removal of the tiles from the table rim. Do not use commercially available ceramic tile cleaners on table frame.

### **SPECIAL WARNINGS!!!**

**PLEASE TAKE PRECAUTION AND DO NOT ALLOW ANYONE TO CLIMB, STAND, CRAWL OR WALK ON TOP OF THE TABLE.**

### **UMBRELLA USAGE WARNING!**

If you will be using an umbrella with your table, make sure the plastic umbrella ring is inserted into the hole in the center of the table. Place the umbrella through the opening and into an umbrella stand made of cast iron, wrought iron, steel plate or blow molded plastic filled with 20-50 lbs or 9-22 kgs of sand or water. If your table is 72" or 182 cm or larger, we recommend a weight of at least 50 lbs or 22 kgs or more. NEVER USE AN UMBRELLA WITH A TABLE WITHOUT USING AN UMBRELLA BASE OR RING AS DESCRIBED ABOVE. ALWAYS REMOVE YOUR UMBRELLA FROM THE TABLE WHEN NOT IN USE. NEVER USE AN UMBRELLA DURING STORMS OR WINDY CONDITIONS.

### **LIMITED WARRANTY**

- **Frames.** Frame construction is warranted against defects in material and workmanship for seven years from purchase date. Damage to frames or welds resulting from improper assembly or exposure to water and/or sub-freezing temperatures is not covered.
- **Finishes.** Paint finishes are warranted against peeling, cracking and blistering for one year from purchase date provided the unit has not been scratched or abraded. Chips and scratches resulting from normal wear and tear are not covered.
- **Fabrics.** Fabric and cushions (if applicable) are warranted against separation at the seams for one year from purchase date. Fading and/or discoloration resulting from exposure to the elements, oils, spills, fluids, chemicals, or any other cause is not covered.
- **Straps and/or wicker.** Straps and/or wicker weave (if applicable) are warranted against separation and tearing for one year from purchase date. Fading and/or discoloration resulting from exposure to the elements, oils, spills, fluids, chemicals, or any other cause is not covered.
- **Umbrellas.** Umbrellas (if applicable) are warranted against defects in material and workmanship only for one year from purchase date. Umbrella bases (if applicable) are not covered under any circumstance.
- **Table tops.** Natural stone tabletops only are warranted against defects in materials or workmanship only for one year from purchase date. All other table tops (including without limitation glass and faux stone) are not covered under any circumstances.

**Warranty limitations:** This warranty is subject to the limitations set forth above. In addition, this warranty is made to the original purchaser only, and is effective only when item(s) is purchased from one of our authorized dealers. This warranty is not transferable. For warranty replacements based on warranty claims submitted within the first year of purchase, we will pay shipping and handling charges within the continental North America. After the first year, shipping and handling charges are your responsibility. We will not be responsible for charges associated with shipments outside the continental North America at any time or for any reason.

**Warranty exclusions:** This warranty is subject to the exclusions as set forth above. In addition, the following are excluded from coverage under this warranty: any item used for commercial, contract or any other non-residential purpose; clearance items, display models or items purchased "as is"; freight damage; items subject to misuse, abuse, neglect or lack of proper care and maintenance (including without limitation as provided in any "care and maintenance guide"); normal wear and tear; damage caused by acts of nature, acts of force majeure, vandalism, fire or other casualty, or improper assembly; hardware against corrosion or rusting; purchased or replacement parts; and all plastic parts. Also excluded are loss of use or time; inconvenience; money; travel; packaging; or incidental, special or consequential damages of any kind. Replacement of defective items as provided herein shall constitute your sole and exclusive remedy for items which are not as warranted. In no event shall our responsibility exceed the purchase price of the items found to be other than as warranted. This warranty is the exclusive statement of your rights with respect to the defects in the items you have purchased and supersedes any other express warranty or statement, written or oral, made in connection with the purchase and sale of such items. When used herein, the term "item" when used in the singular, refers to the specific item found to be defective, and not to the entire set of which the item is a part.

**Some states do not allow exclusion or limitation of incidental or consequential damages, so that limitation above may not apply to you. This warranty gives you specific legal rights, and you may also have other rights which vary from state to state.**

# **PATIO FURNITURE & ACCESSORIES ASSEMBLY INSTRUCTIONS**

## **IMPORTANT!!!**

**STOP! PLEASE READ THESE INSTRUCTIONS CAREFULLY BEFORE ASSEMBLY. MAKE SURE YOU HAVE ALL THE PARTS AND HARDWARE AS IDENTIFIED ON THE PARTS LIST.**