









# ASSEMBLY INSTRUCTIONS

**ATTENTION: THIS PRODUCT IS NOT FOR COMMERCIAL USE.  
INTENDED FOR RESIDENTIAL USE ONLY.**

## TMS63PK

### PARTS LIST

PART NO.	MATERIAL CODE	PART	Q'TY	PART NO.	MATERIAL CODE	PART	Q'TY
1	TMS63PK-CS05-1	 TABLE TOP	1	5	17C40A0705001YX	 BOLT M6*15	14
2	TMS63PK-CS04-1	 LEG	4	6	17C40A0709001YX	 BOLT M6*25	2
3	TMS63PK-CS04-2	 SUPPORT	2	7	17KAA0101----Y4	 HEX. KEY WRENCH 4MM	1
4	62TMS63PKY101	 CENTER CONNECTOR WITH RING	1	8	17KAC3101----Y3	 HEX. KEY WRENCH 10MM	1

**Attention:**  
Make sure that each bolt needed for all steps matches the corresponding figure to ensure proper assembly.

**Step 1:**  
Place the table top (#1) onto a non-abrasive surface, such as a carpet, with its underside facing upwards. Fasten the legs (#2) and the supports (#3) to the underside of the table top (#1) rim by using bolts (#5). Keep the bolts loose. See Figure 1.

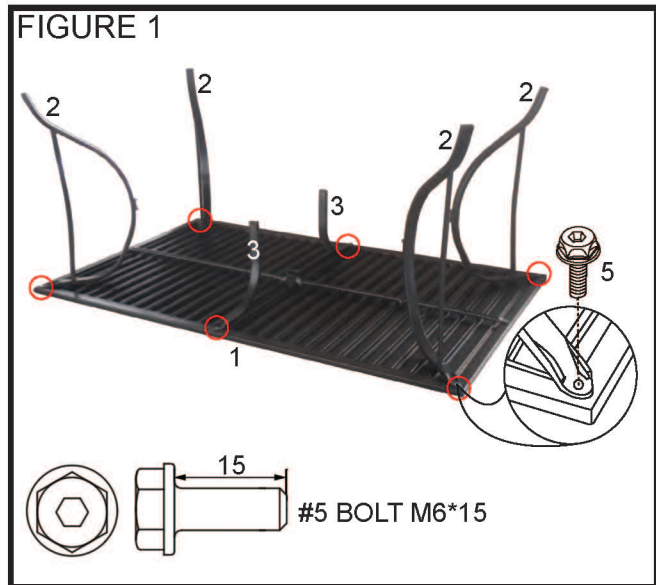

- ⚠ Use the correct bolts as indicated. Do not tighten any of the bolts until the table is completely assembled.
- ⚠ Do not sit or stand on this table.
- ⚠ A weighted umbrella base must be used when using an umbrella with this table.
- ⚠ Do not discard any of the packaging until you have checked that you have all of the parts and fittings required.
- ⚠ Keep children away during assembly. This item contains small parts that can be swallowed by children. Children should always be under direct adult supervision while using this product.
- ⚠ Retain these assembly instructions for future reference.
- ⚠ Quote the following FQC No. when contacting the service center.

SERVICE CENTER TOLL FREE NO.  
TEL: 1-877-539-7436  
FAX: 1-877-539-7439

FIGURE 2

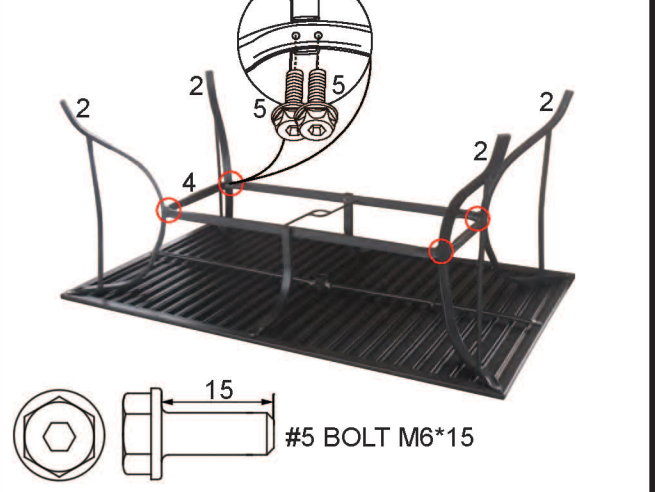

Step 2:  
Fasten the center connector with ring (#4) to the middle of the legs (#2) by using bolts (#5). Keep the bolts loose. See Figure 2.

FIGURE 3

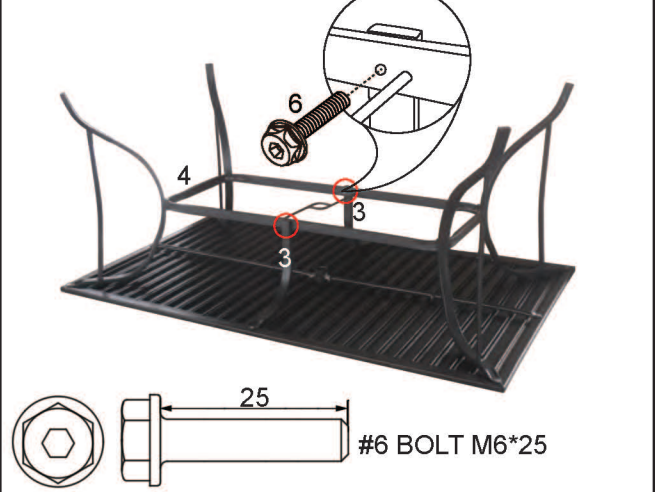

Step 3:  
Fasten the center connector with ring (#4) to the supports (#3) by using bolts (#6). Make sure that all of the bolts have been tightened completely. See Figure 3.

FIGURE 4



Step 4:  
Turn the table to its upright position. See Figure 4.

**Note:**  
To use an umbrella with this table, remove the center plug and put the umbrella pole through the table top and center connector ring.

Cleaning and Maintenance

- Wash frame parts with mild soap and water, rinse thoroughly, and dry completely. Do not use bleach, acid, or other solvents on the frame parts.
- Inspect and tighten all of the bolts and fasteners on a regular basis to ensure the proper performance and safety of your table.
- When moving the table, remove the umbrella and lift. Do not drag this table.
- We recommend the use of furniture covers when not in use.
- In order to prolong the life and beauty of your table, we recommend that it be stored in a dry and protected area during off season periods.
- The umbrella should be lowered and/or removed in windy conditions.

Warranty

- This product is covered by Courtyard Creations Inc.'s one-year limited warranty.
- Proof of purchase (dated register receipt) is required for warranty claims.
- It remains the customer's responsibility for freight and packing charges to and from the service center.

**STOP!**  
Missing A Part?  
No Need To Go Back To  
The Store

The store where you made your purchase does not stock parts for this item. If you need parts, whether they are missing or damaged, Call Toll Free:

TEL: 1-877-539-7436  
FAX: 1-877-539-7439  
Call us between 9:00 AM and 4:30 PM Eastern Time Monday through Friday  
For further assistance, please visit us at [service.cci@polywares.com](mailto:service.cci@polywares.com)

READ THESE INSTRUCTIONS COMPLETELY BEFORE STARTING ASSEMBLY

- ★ SEPARATE AND IDENTIFY ALL OF THE PARTS, MAKING SURE THAT YOU HAVE ALL OF THE PARTS LISTED.
- ★ IF YOU DO NOT LOCATE ALL OF THE PARTS LISTED, INSPECT THE PACKING MATERIAL FOR SMALL PARTS THAT MAY HAVE BECOME SEPARATED DURING SHIPMENT.
- ★ IF YOU EXPERIENCE ANY DIFFICULTY DURING ASSEMBLY OR IF ANY PARTS ARE MISSING OR DAMAGED, CALL THE HELP LINE AT 1-877-539-7436 BEFORE RETURNING THIS ITEM TO THE STORE.
- ★ PROVIDE THE FOLLOWING INFORMATION WHEN CALLING:  
1-MODEL NUMBER OF THE PRODUCT.  
2-PART NUMBER AND MATERIAL CODE OF THE PART FROM THE PARTS LIST.
- ★ MOST PROBLEMS CAN BE RESOLVED WITHOUT RETURNING THIS PRODUCT TO THE RETAILER.