

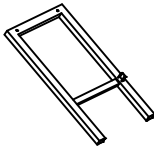

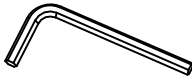

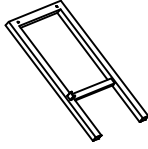

NO.	PART	DESCRIPTION	Q'TY	NO.	PARTS	DESCRIPTION	Q'TY
A		Left Side Panel	1PC	E		Allen Head Wrench 4MM	1PC
B		Right Side Panel	1PC	F		Allen Head Bolt $\frac{1}{4} \times \frac{7}{8}$ "	6PCS
C		Seat Panel	1PC	G		Spring Washer < F€	6PCS
D		Connect Pipe	1PC	H		Flat Washer < F€<F€	6PCS

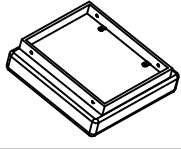

## STEP 2

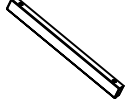
Attach the connect bar (D) onto the left panel (A) by inserting the metal joint into the corner bar (D) and screwing the Allen head bolt (F) through the spring washer (G) and flat washer (H).

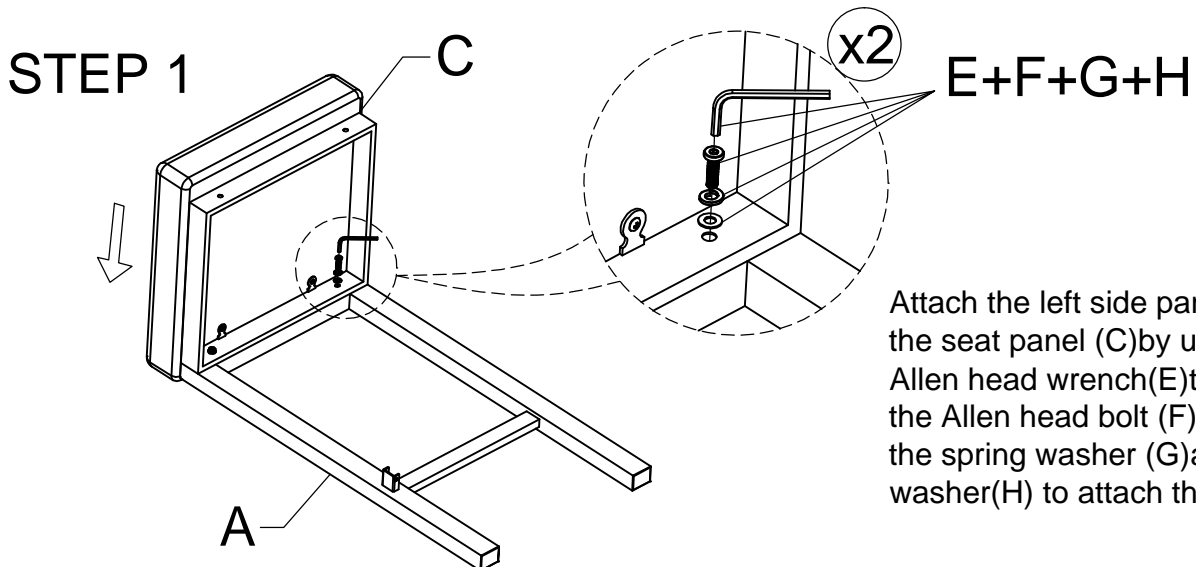
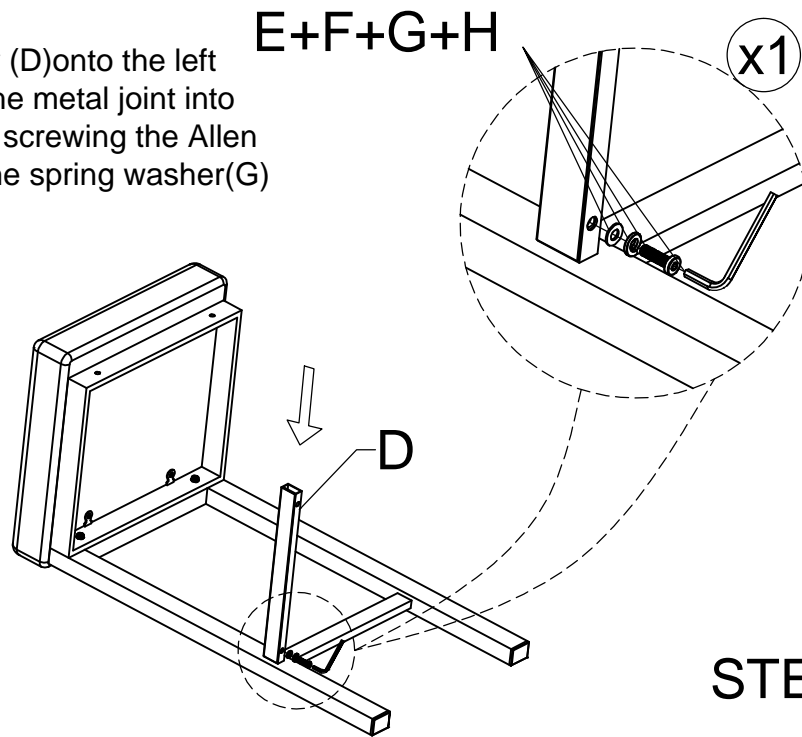

## STEP 3

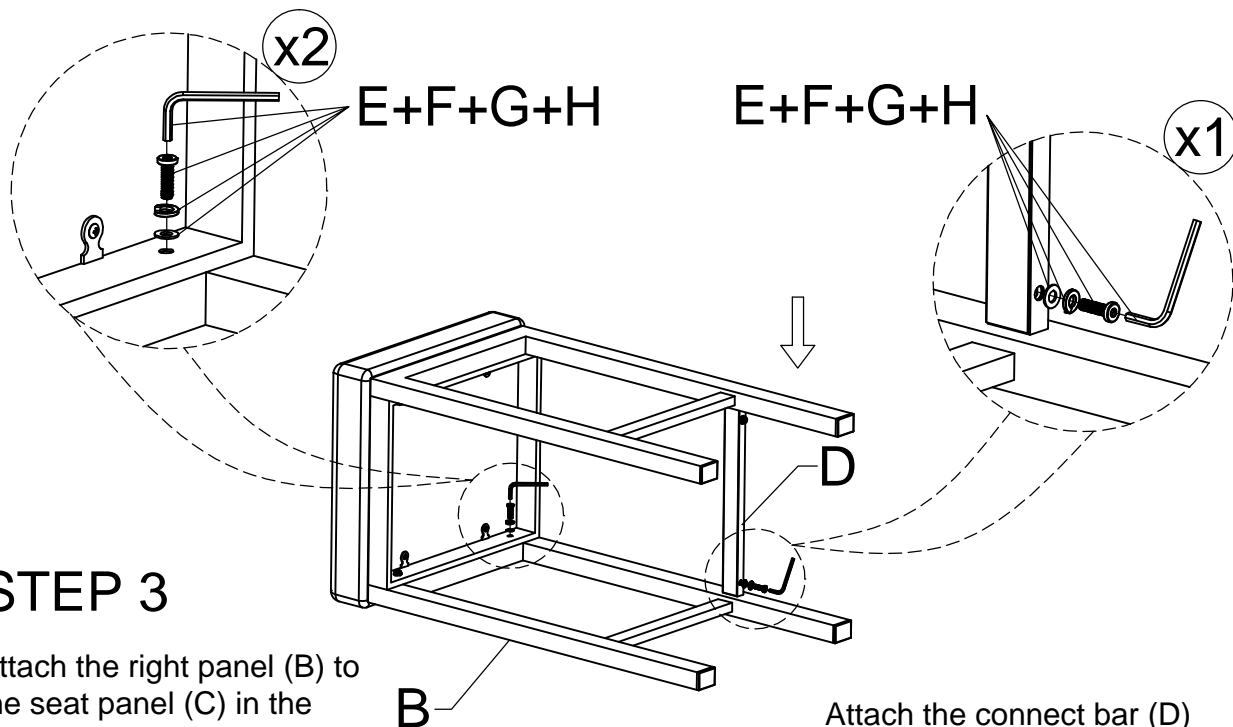





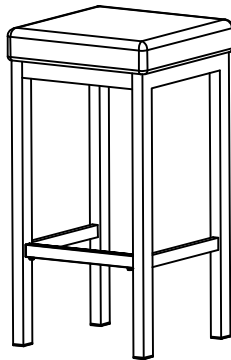

## STEP 3

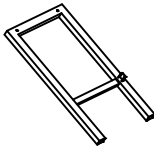
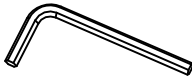
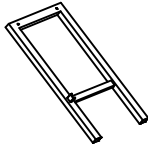
Attach the right panel (B) to the seat panel (C) in the same way as in step 1.

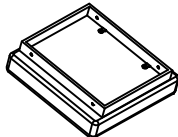
Attach the connect bar (D) to the right side panel (B) in the same way as in step 2.

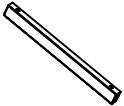

NO.	PART	DESCRIPTION	Q'TY	NO.	PARTS	DESCRIPTION	Q'TY
A		Panneau	1PC	E		7 f' dci f' h. lly { six pans creux 4mm	1PC
B		Panneau	1PC	F		6ci 'cb' dci f' h. lly { 'gl' d' lbg' W' l 1/4 Po * 7/8 "Po	6PCS
C		Panneau du siège	1PC	G		Ü [ } â^   ^ Áe ! ^ • • [ ! o^ Á F e [ {	6PCS
D		Tuyau de raccordement	1PC	H		Rondelle plate < FCEVFE	6PCS

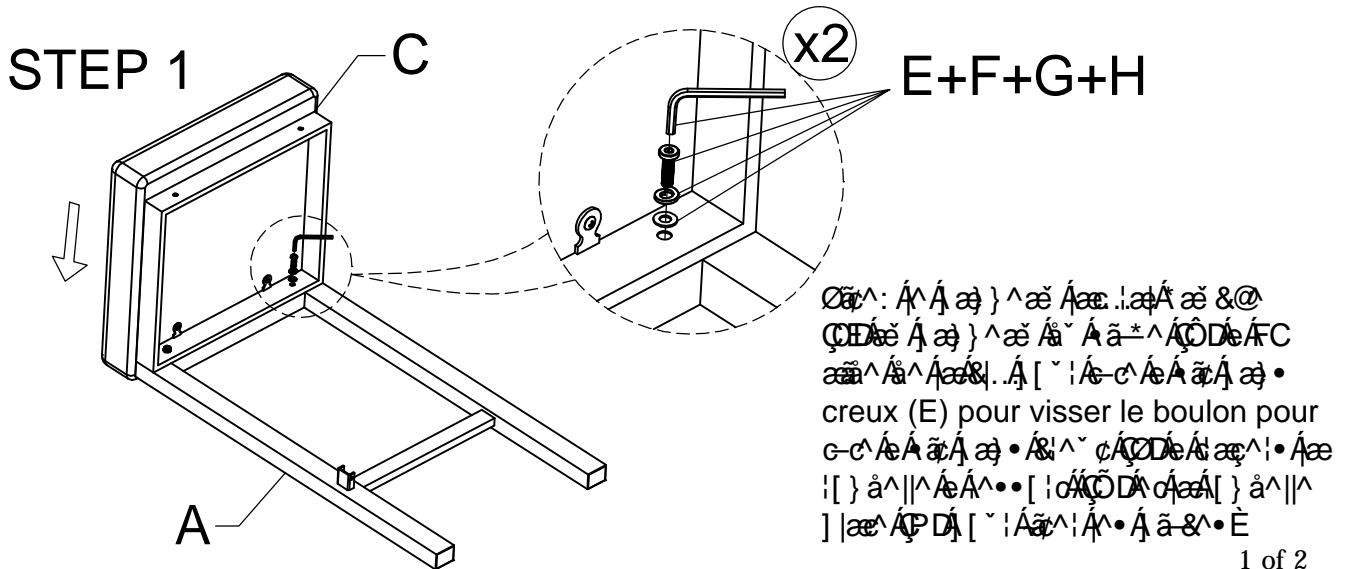

## STEP 2

Fixez la barre de raccordement (D) sur le  
 ] æ } ^ æ Á æ & @ Á Ç D Á } Á • . . i æ ç ^ Á } c  
 ^ } Á . . ç Á æ } Á æ á æ ! ^ Á } Á & [ á Á Ç D Á }  
 ç á • æ ç Á Á [ ^ [ ] Á [ ^ ! Á c Á æ Á æ •  
 & ^ ^ Ç Á Ç D Á æ ^ ! Á æ Á [ } á ^ | ^ Á Á • • [ í c  
 (G) et la rondelle plate (H)

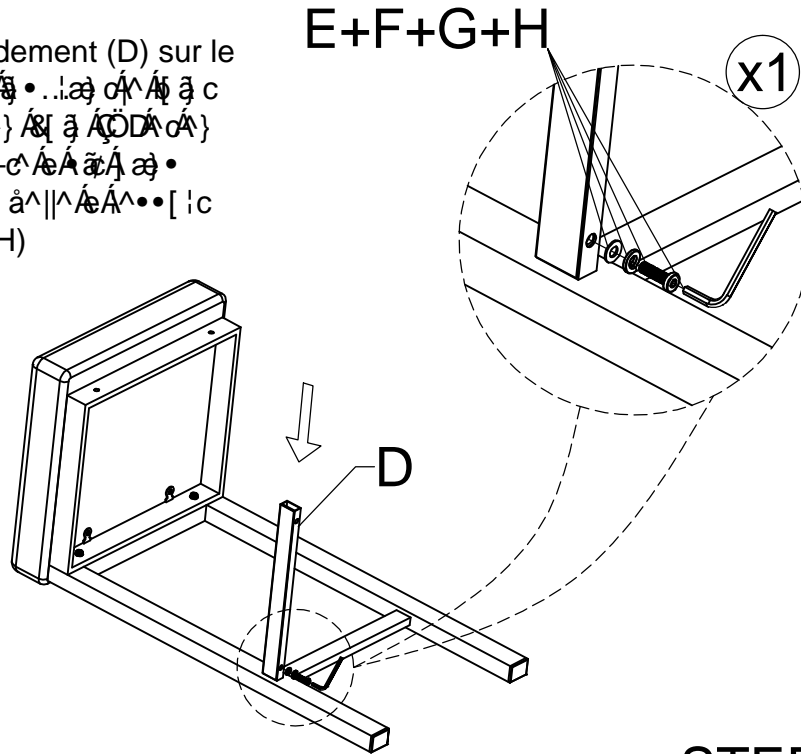

## STEP 3

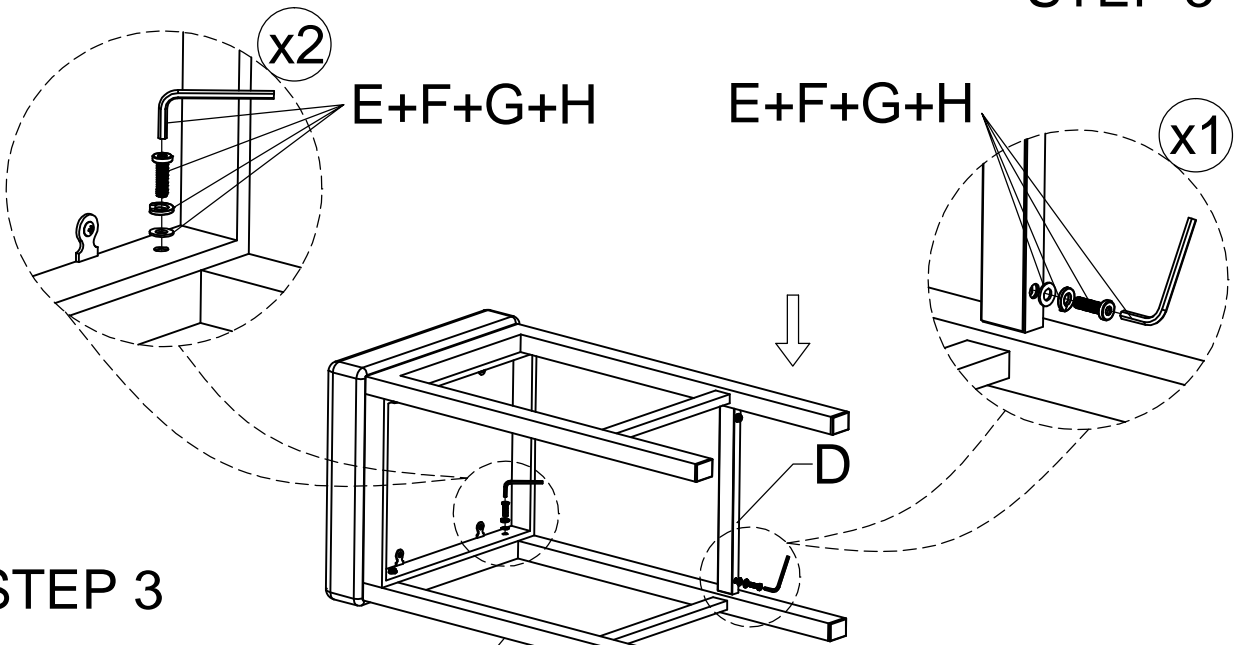





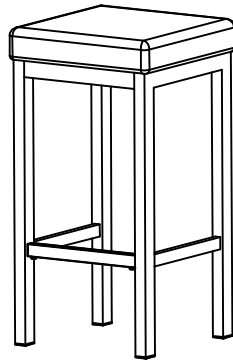

## STEP 3

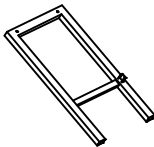
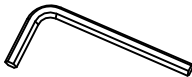
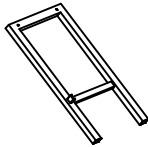
Fixez le panneau droit (B) au  
 ] æ } ^ æ Á æ Á æ \* ^ Á Ç D Á } Á æ  
 { - { ^ Á æ [ } Á ^ Ç Á Ç D Á } Á È B

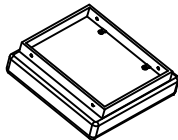
Fixez la barre de raccordement (D)  
 æ Á æ } ^ æ Á æ . . i æ á | á Á Ç D Á } Á æ  
 { - { ^ Á æ [ } Á ^ Ç Á Ç D Á } Á È

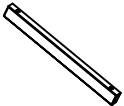

NO.	PART	DESCRIPTION	Q'TY	NO.	PARTS	DESCRIPTION	Q'TY
A		Panel lateral izquierdo	1PC	E		Llave de cabeza Allen 4mm	1PC
B		Panel lateral derecho	1PC	F		Perno de cabeza Alen $\frac{1}{4} * \frac{7}{8}$	6PCS
C		Panel de asiento	1PC	G		Arandela de presi5n <math>\frac{1}{4}</math>	6PCS
D		Tubo de <math>\frac{1}{4}</math>	1PC	H		arandela plana <math>\frac{1}{4}</math>	6PCS

**STEP 1**  **E+F+G+H**

Conecte el panel lateral izquierdo (A) al Panel del asiento(C)utilizando la llave allen (E) para atornillar el arandela plana (H) para conectar las partea

## STEP 2

Conecte el panel izquierdo (A) al panel del asiento (C) de metal en la barra de esquina (D) y atornillando el perno de cabeza allen (F) con la arandela plana (H)

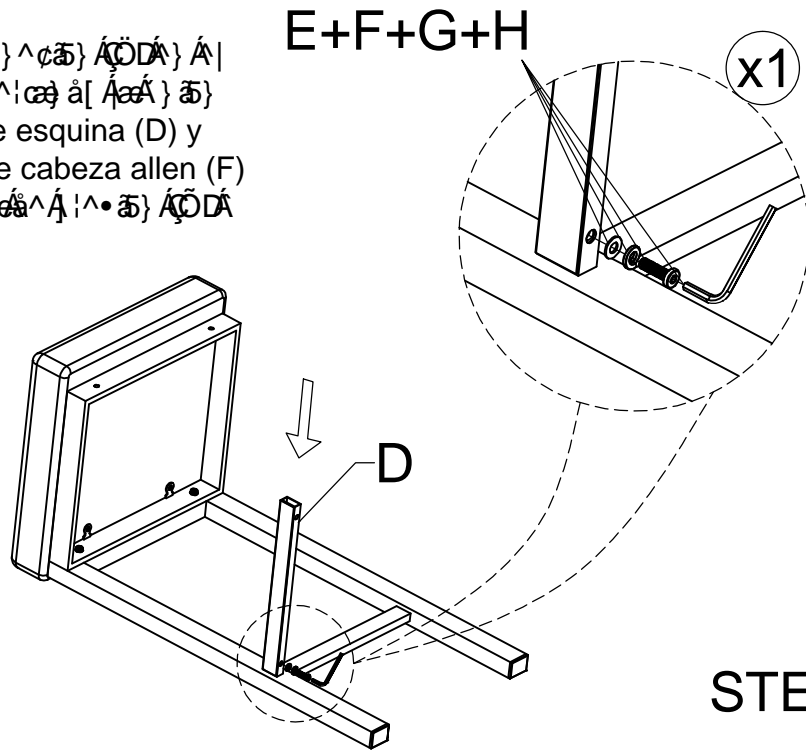

## STEP 3

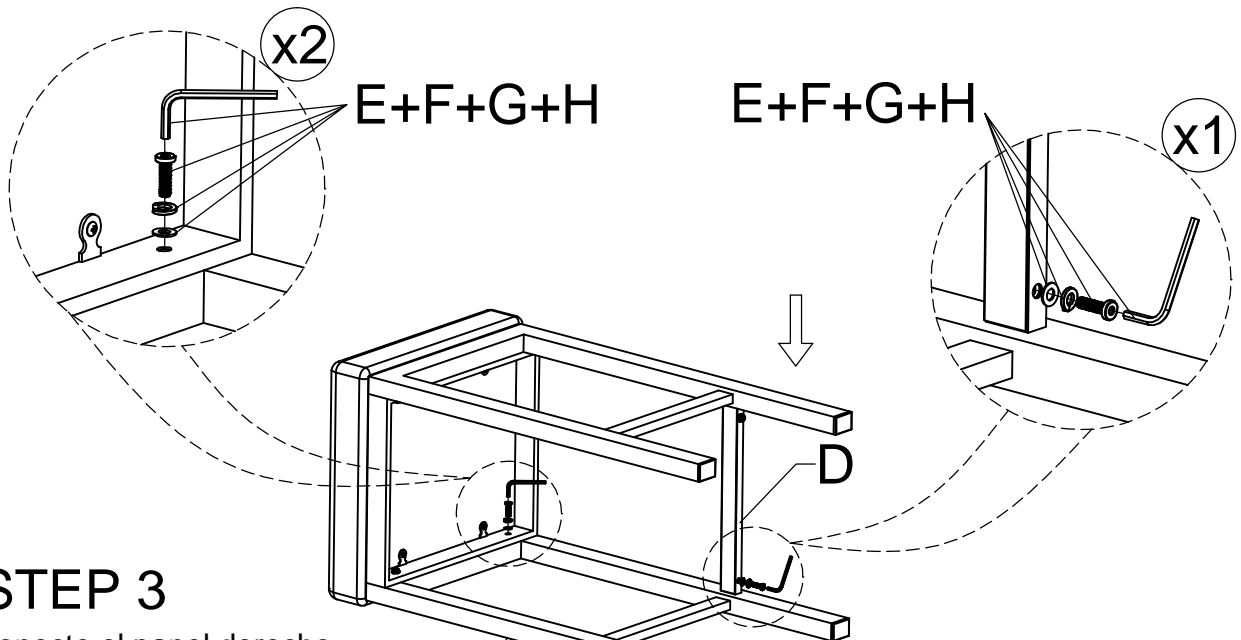

## STEP 3

Conecte el panel derecho (B) al panel del asiento (C) de la misma manera que en el paso 1.

Conecte el panel lateral derecho (B) de la misma manera que en el paso 2.