

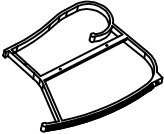

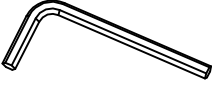

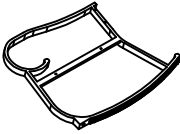

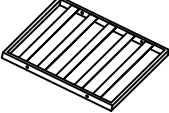

NO.	PART	DESCRIPTION	Q'TY	NO.	PARTS	DESCRIPTION	Q'TY
A		Left Arm	1PC	G		Allen Head Wrench 4MM	1PC
B		Right Arm	1PC	H		Allen Head Bolt $\frac{1}{4} \times 1\frac{3}{4}+$	4PCS
C		Seat Panel	1PC	I		Allen Head Bolt $\frac{1}{4} \times 1\frac{1}{8}+$	4PCS
D		Back Panel	1PC	J		Spring Washer < F€	8PCS
E		Back Cushion	1PC	K		Flat Washer < F€	8PCS
F		Seat Cushion	1PC				

STEP 1

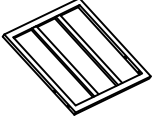

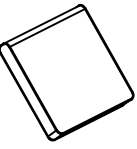
Using the Allen head wrench (G) screw the Allen head bolt (H) through the spring washer (J) and back panel (D) on to the left Arm (A).

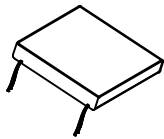
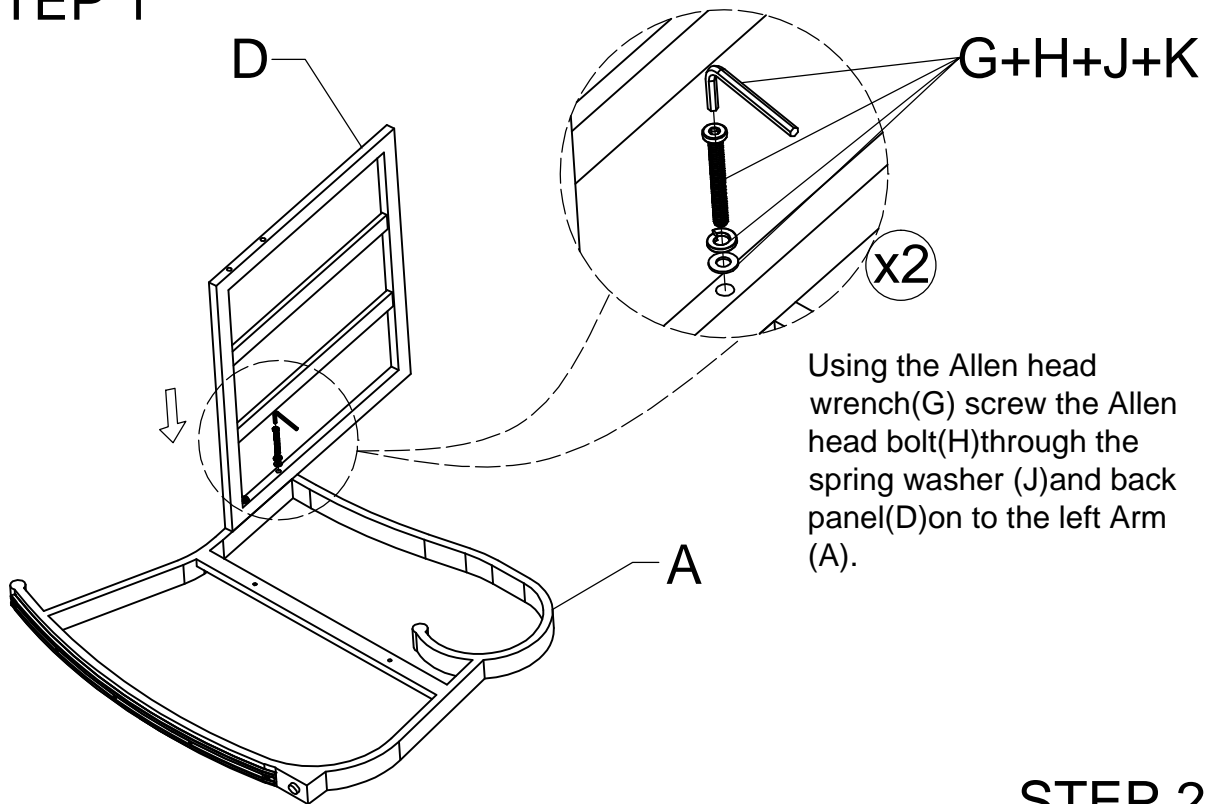
STEP 2

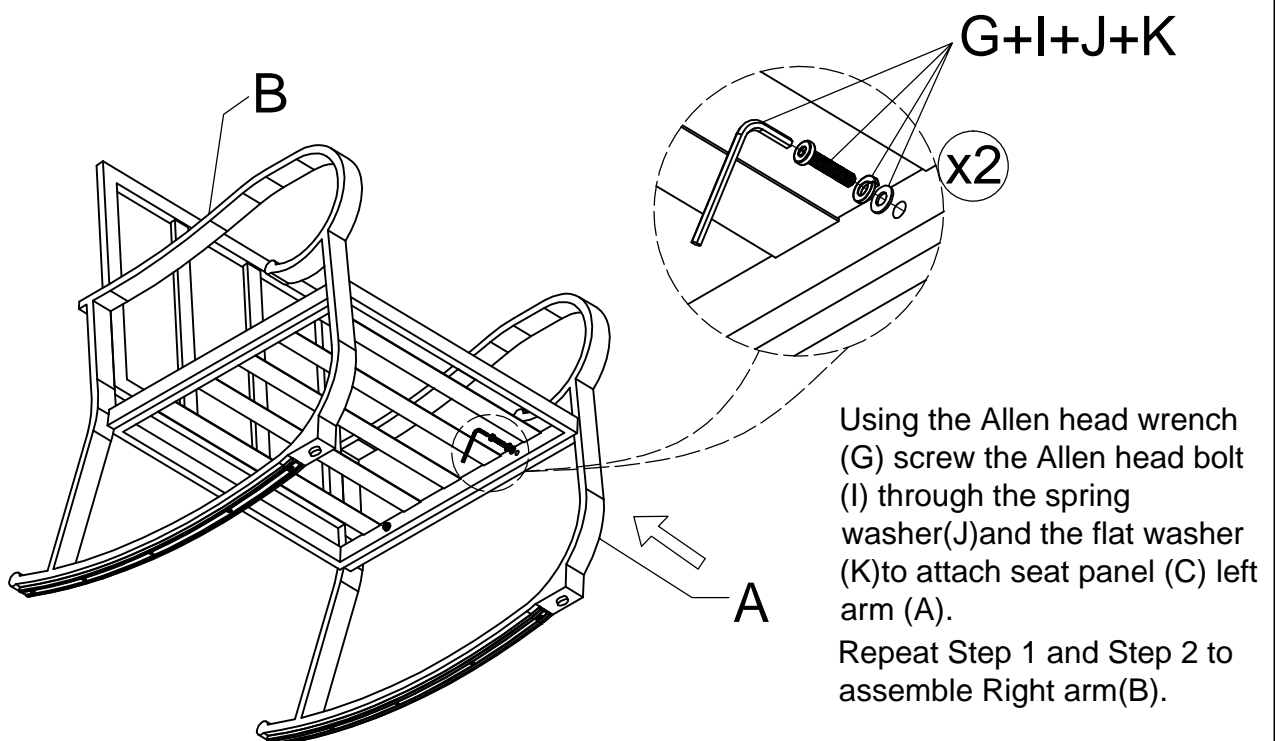

Using the Allen head wrench (G) screw the Allen head bolt (I) through the spring washer (J) and the flat washer (K) to attach seat panel (C) left arm (A).





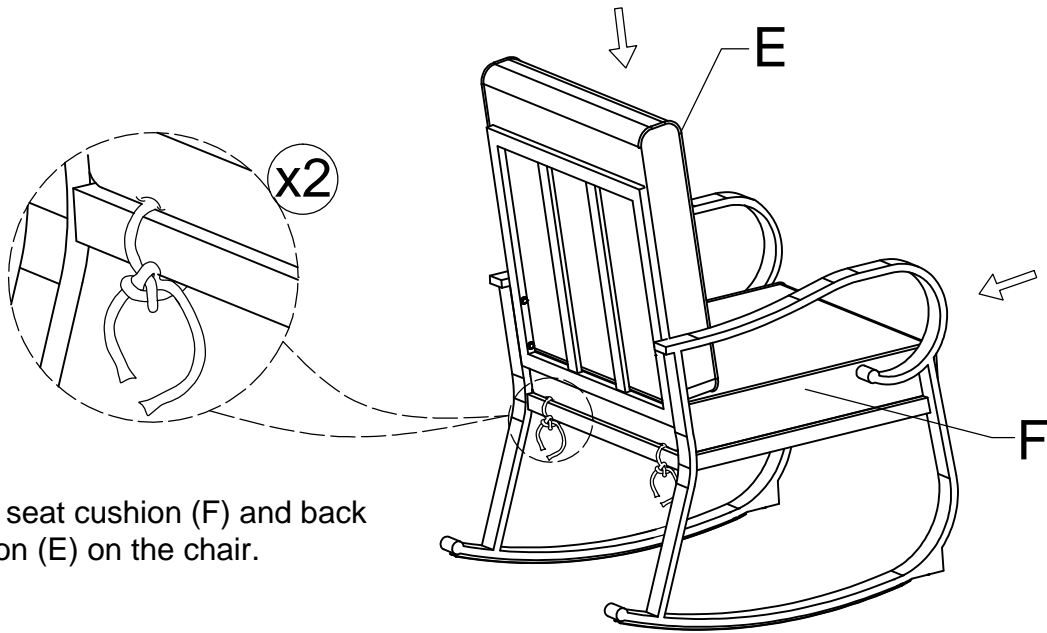

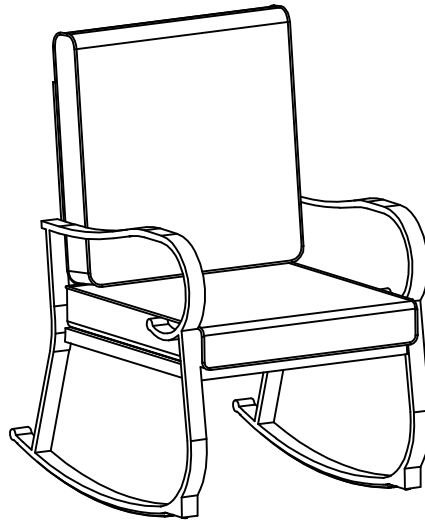

Repeat Step 1 and Step 2 to assemble Right arm (B).

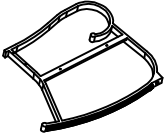
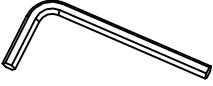
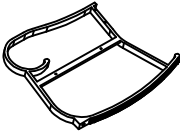
STEP 3

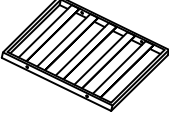

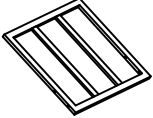
Place seat cushion (F) and back cushion (E) on the chair.

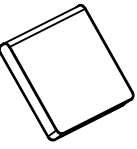

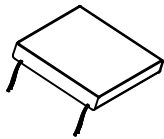
NO.	PART	DESCRIPTION	Q'TY	NO.	PARTS	DESCRIPTION	Q'TY
A		Bras gauche	1PC	G		Ôl. Á[~!A-e eÁãAæ• creux 4mm	1PC
B		Bras droit	1PC	H		6ci `cb'dci f'h.l.Y { 'gll 'dUbg'WYi l ¼ Po × 1¼" Po	4PCS
C		Siege panneau lateral	1PC	I		6ci `cb'dci f'h.l.Y { 'gll 'dUbg'WYi l ¼ Po × 1½" Po	4PCS
D		Dossier panneau lateral	1PC	J		Ü[} â\ Aé !••[!A FÉ{ {	8PCS
E		Coussin de dossier	1PC	K		Rondelle plate < FGEV/FÉE	8PCS
F		Coussin de siège	1PC				

STEP 1

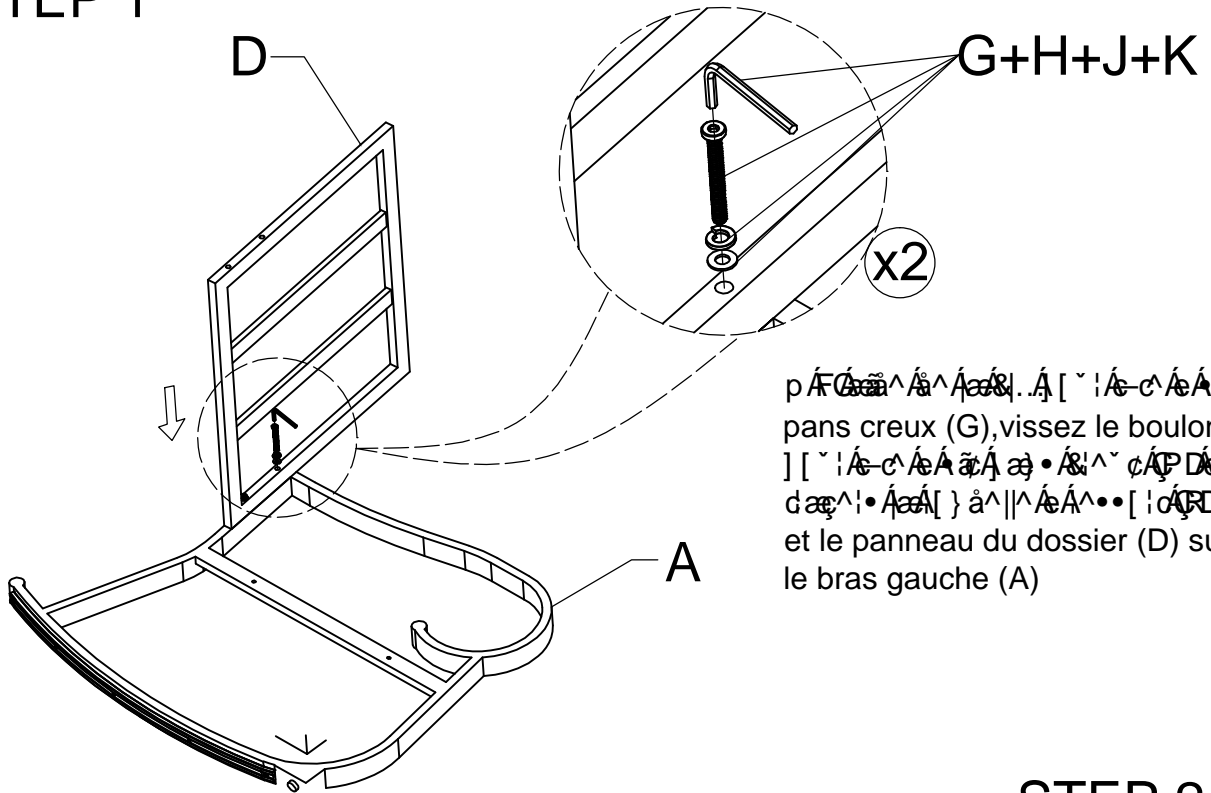

p

 ans creux (G), vissez le boulon

 et le panneau du dossier (D) sur

 le bras gauche (A)

STEP 2

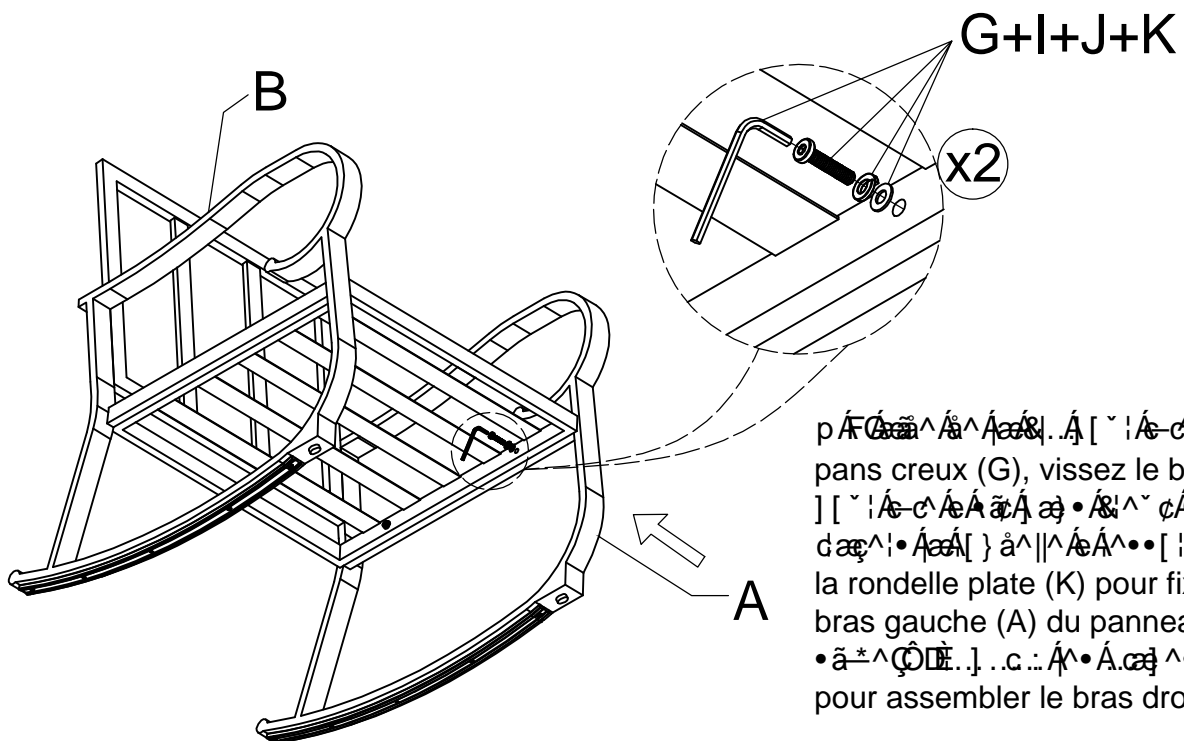

p

 ans creux (G), vissez le boulon

 la rondelle plate (K) pour fixer le

 bras gauche (A) du panneau du





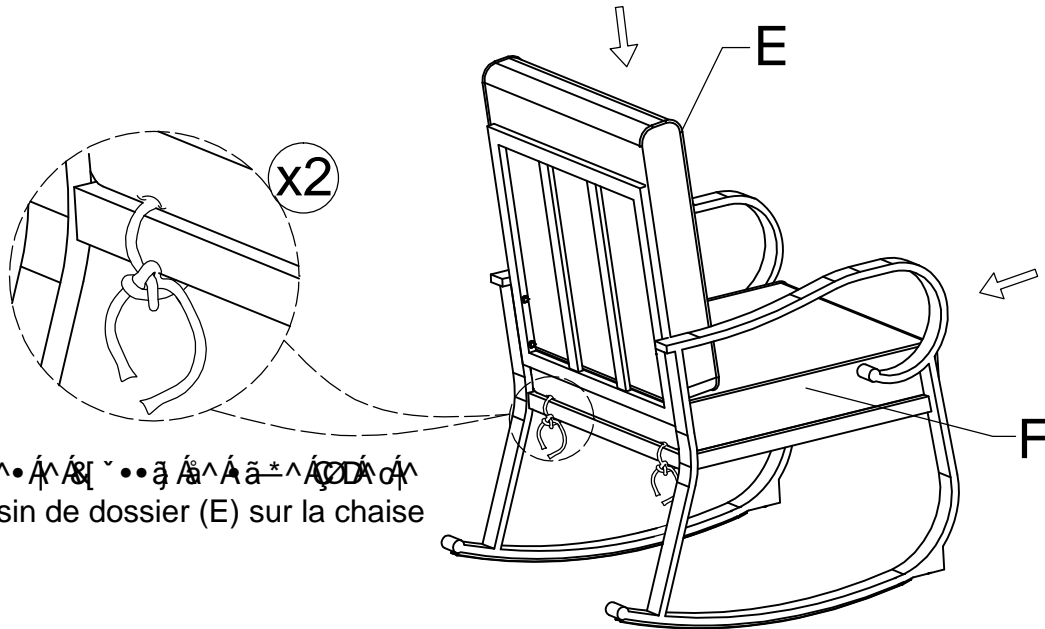

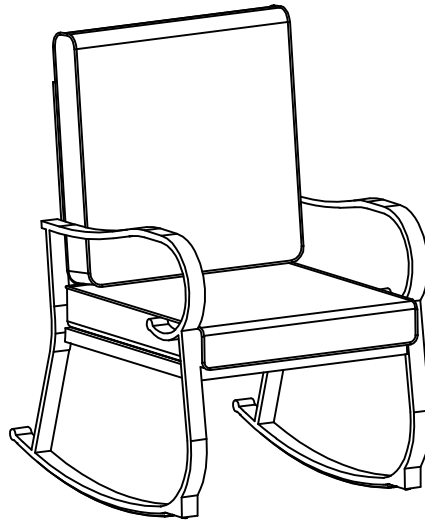

 pour assembler le bras droit (B)

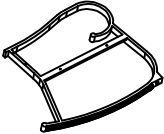
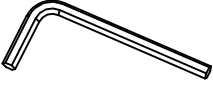
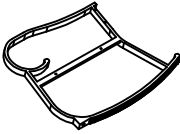
STEP 3

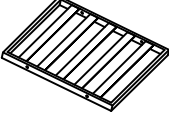

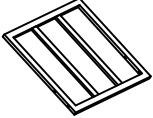
Úlæ•Á•Á•••ã Á•Á••^Á•Á•
cousin de dossier (E) sur la chaise

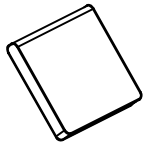

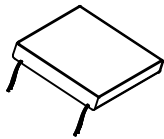
NO.	PART	DESCRIPTION	Q'TY	NO.	PARTS	DESCRIPTION	Q'TY
A		Brazo izquierdo	1PC	G		Llave de cabeza allen 4mm	1PC
B		Brazo derecho	1PC	H		Perno de cabeza alen $\frac{1}{4} * \frac{1}{4}$ "	4PCS
C		Panel de respaldo	1PC	I		Perno de cabeza alen $\frac{1}{4} * \frac{1}{8}$ "	4PCS
D		Panel de asiento	1PC	J		Arandela de $\frac{1}{4}$ "	8PCS
E		Óp[] / ^ respaldo	1PC	K		Arandela la $\frac{1}{4}$ "	8PCS
F		Óp[] / ^ asiento	1PC				

STEP 1

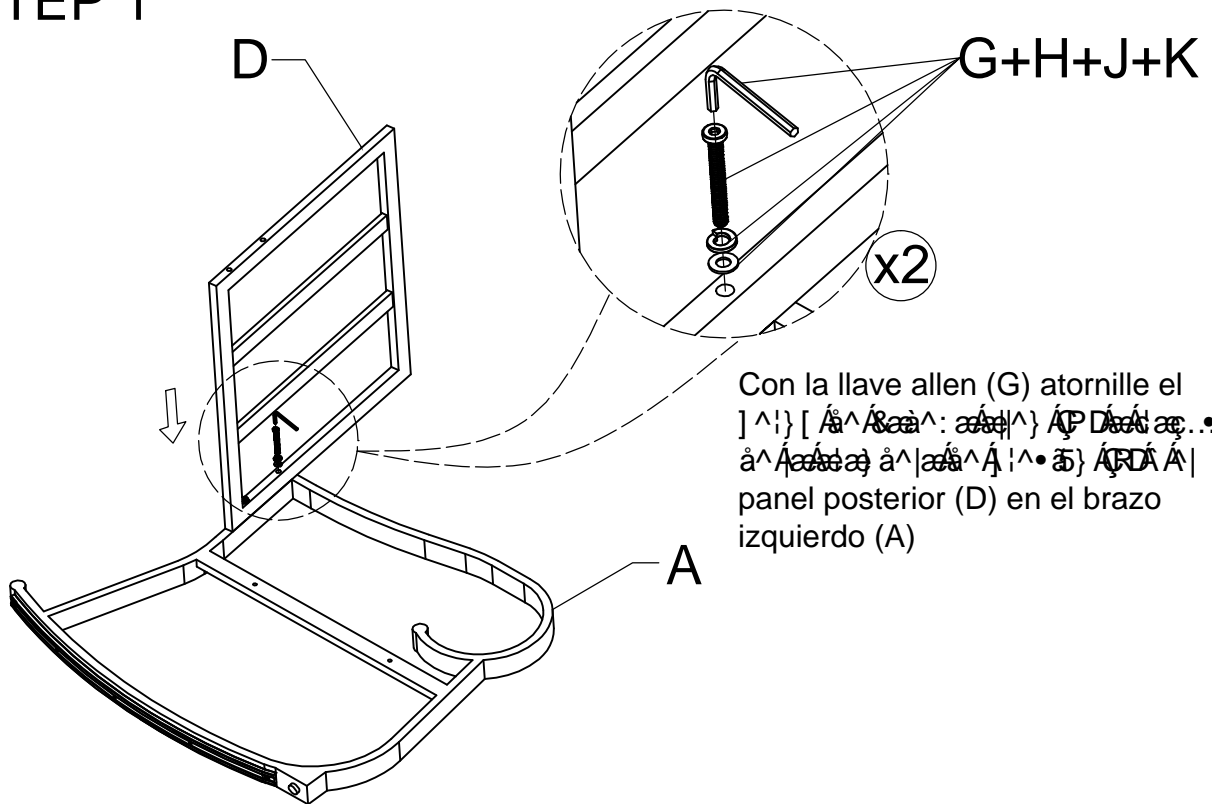

STEP 2

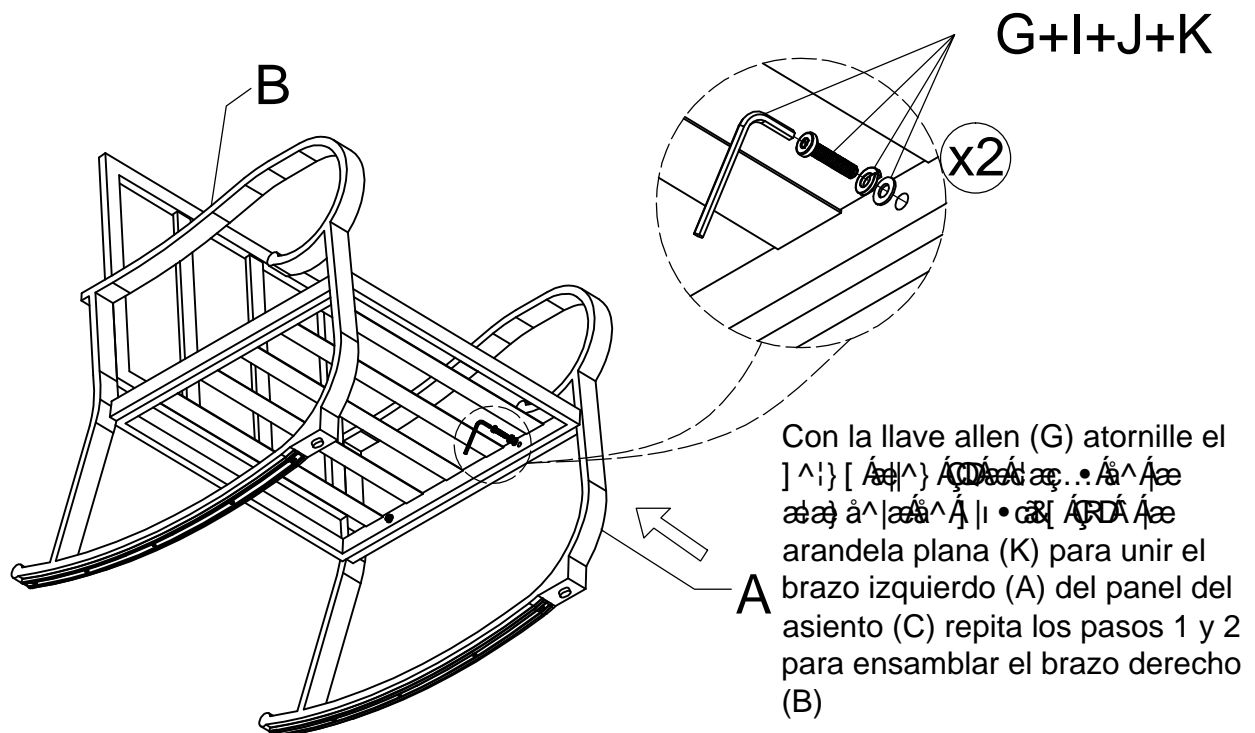

STEP 3

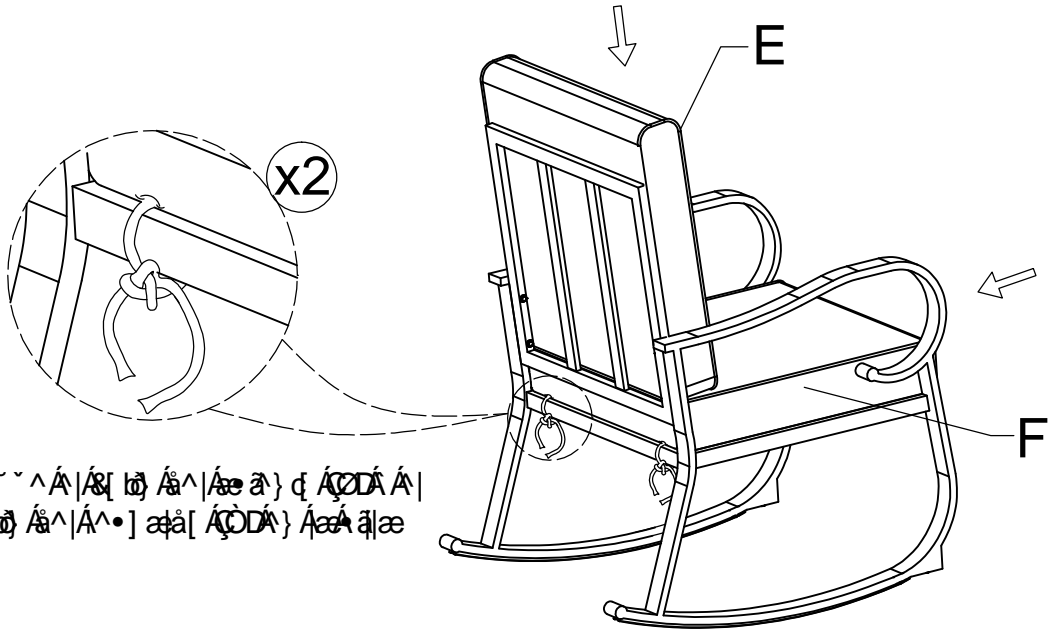

Ô[[[^ Á | & [ð Á ^ | Á e a } ç Á Ç D Á Á |
& [ð Á ^ | Á ^ •] ç ð [Á Ç D Á } Á e Á ð | e