



FS Carring Coffee Table

RXTV-1822-CT/227453

Assembly Instructions

Step 1: Remove protective wrapping first. Then lay all parts on floor and identify all parts packed in carton against attached parts list.

Step 2: Lay Table Top Frame (A) upside down on floor, so bottom is facing up. Place a protective soft material on floor before placing table top face down on floor. Then attach each of Side Legs (B) to the bottom ,using Bolt (D) and Washer (E) and Bolt cover(F) as shown in Diagram 1.

Step 3: Then attach the Bottom Shelf (C) to the legs (B) ,using Bolt (D), Washer (E) , and Bolt Cover(F) as shown in Diagram 2.

Step 4: Make sure all bolts are aligned properly and tightened sufficiently. Then place bolt covers over bolts and turn the table over onto it's legs carefully using a flat surface as shown in Diagram 3.

NOTE: IT IS USER'S RESPONSIBILITY TO MAKE SURE ALL PARTS ARE ASSEMBLED AND TIGHTENED PROPERLY AND SECURELY.

WARNING!: TABLE IS NOT MEANT FOR SITTING. DO NOT SIT OR LEAN FULL BODY AGAINST TABLE.

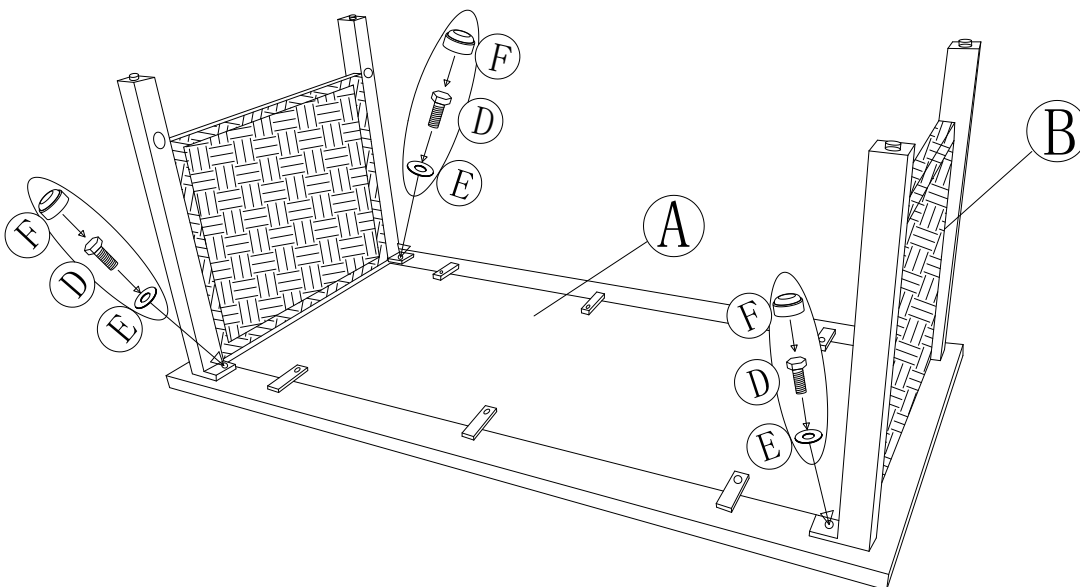

Diagram 1

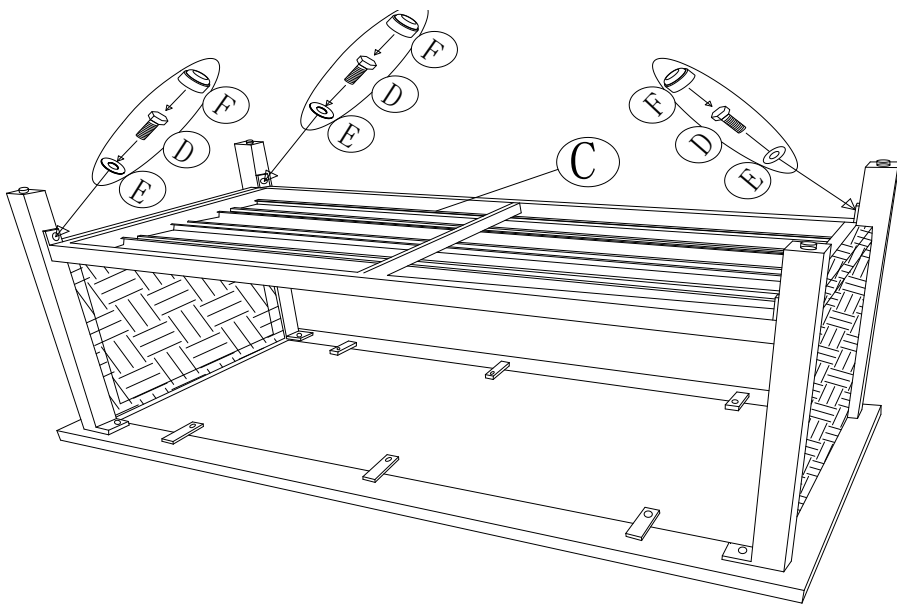

Diagram 2

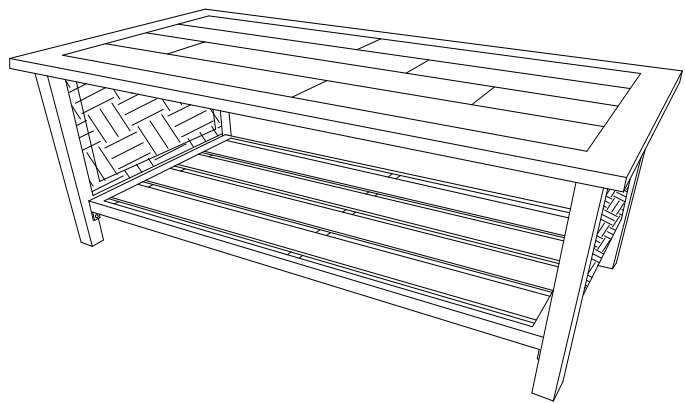
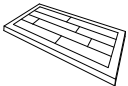



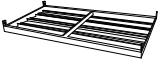
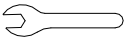
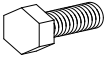

Diagram 3

PARTS LIST

Ref	Part Name	Part Image	Qty	Ref	Part Name	Part Image	Qty
A	Table Top		1	E	Washer (M6)		8
B	Side Legs		2	F	Bolt Cover		8
C	Bottom Shelf		1	G	Kex Wrench		1
D	Bolt		8				

WOODARD
Customer Service Hours
8:00am-5:00pm CST Monday to Friday
Phone: (800) 877-2290 Fax: (800) 733-4257

PRINTED IN CHINA