



FS Carring Loveseat RXTV-1822-LS/227458 Assembly Instructions

Step 1: Remove protective wrapping first. Then lay all parts on floor and identify all parts packed in carton against attached parts list.

Step 2: Lay Chair Seat Frame (B) down on floor. Then attach Chair Back (A) to the seat, using Bolt (D) and Washer (F) and Bolt cover (G) as shown in Diagram 1.

Step 3: Then attach the Right/Left Arm Panel (C) to the Seat (B) and Back (A), using Bolt (D), Bolt (E), Washer (F), and Bolt Cover (G) as shown in Diagram 2.

Step 4: Make sure all bolts are aligned properly and tightened sufficiently. Then place bolt covers over bolts.

NOTE: IT IS USER'S RESPONSIBILITY TO MAKE SURE ALL PARTS ARE ASSEMBLED AND TIGHTENED PROPERLY AND SECURELY.

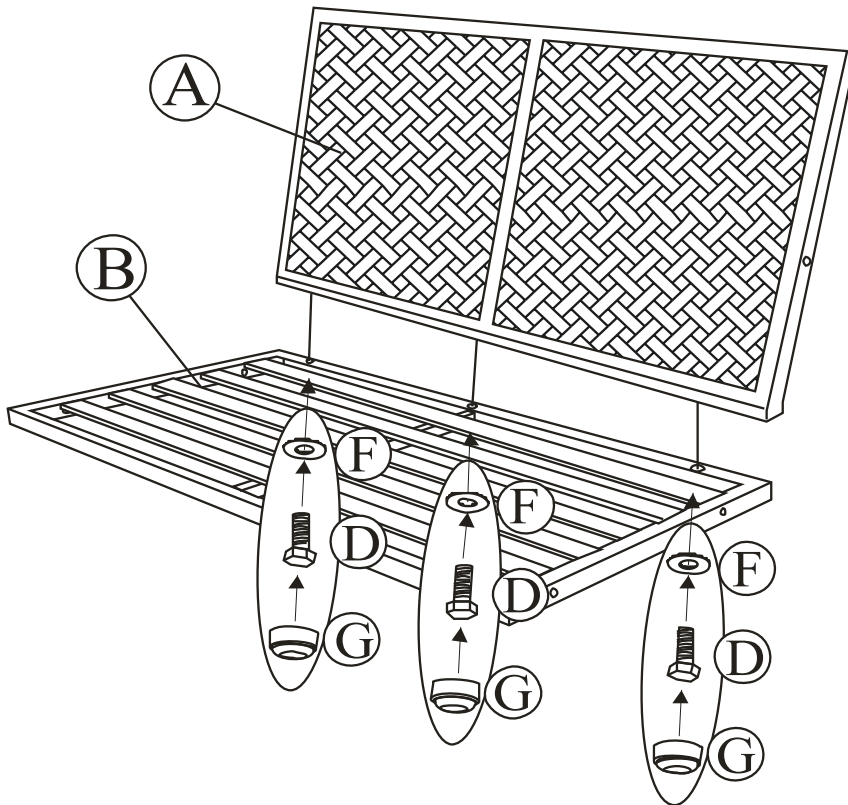

Diagram 1

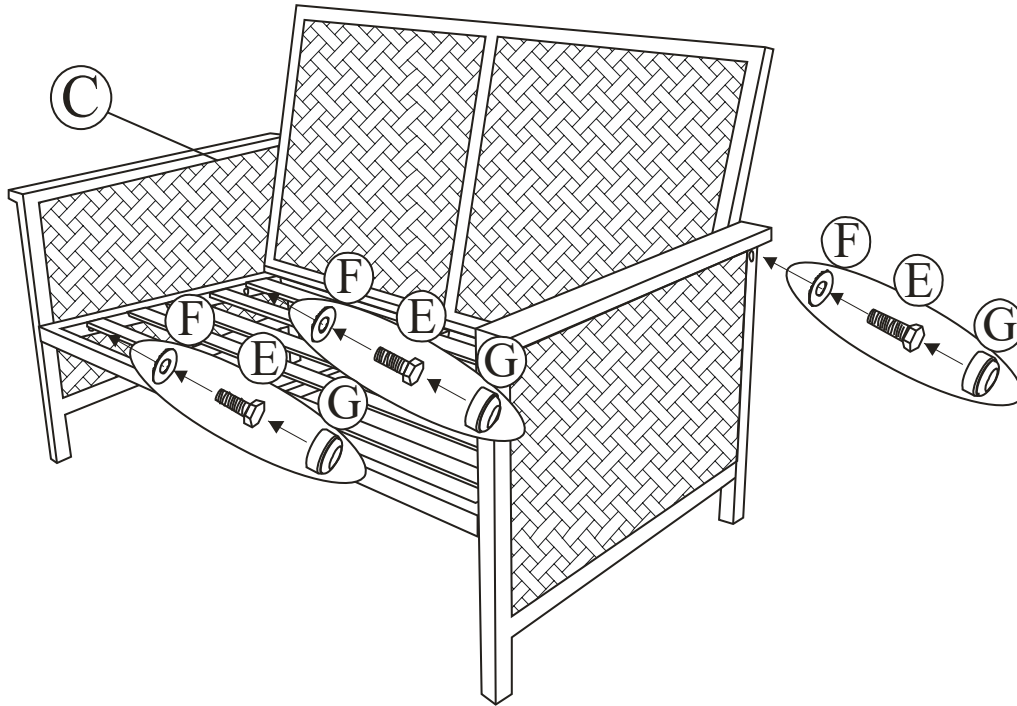
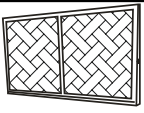
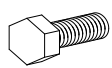

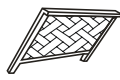

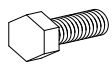



Diagram 2

PARTS LIST

Ref	Part Name	Part Image	Qty	Ref	Part Name	Part Image	Qty
A	Chair Back		1	E	Long Bolt		6
B	Chair Seat		1	F	Washer (M6)		9
C	Right/Left Arm Panel		2	G	Bolt Cover		9
D	Short Bolt		3	H	Hex Wrench		1

WOODARD
Customer Service Hours
8:00am-5:00pm CST Monday to Friday
Phone: (800) 877-2290 Fax: (800) 733-4257

PRINTED IN CHINA