

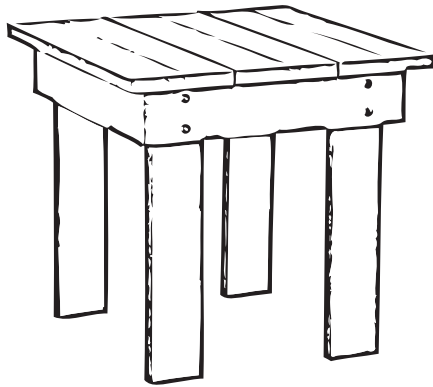



ALL-WEATHER POLY SIDE TABLE

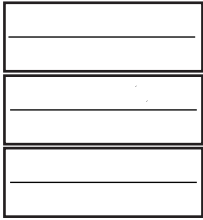

TX 94041

TX 94044

PARTS AND HARDWARE LIST	
①	②
 <p>X 4PCS</p>	 <p>X 1PC</p>
 <p>A</p>	
<p>BOLT X 8PCS</p>	

Tools Included



STEP 1:

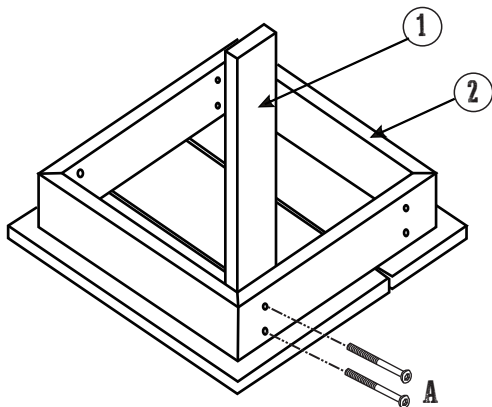

STEP 2:

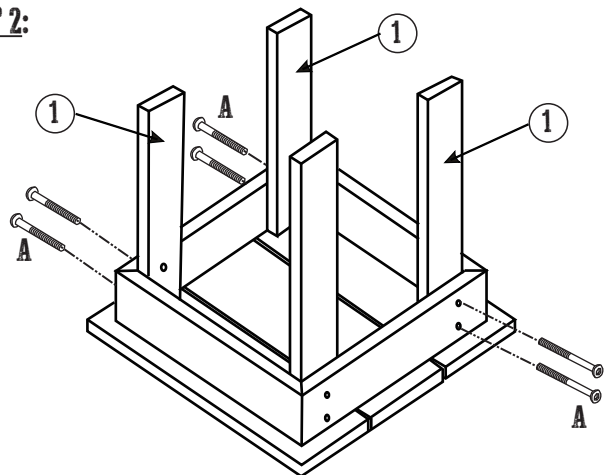

STEP 4: Finish

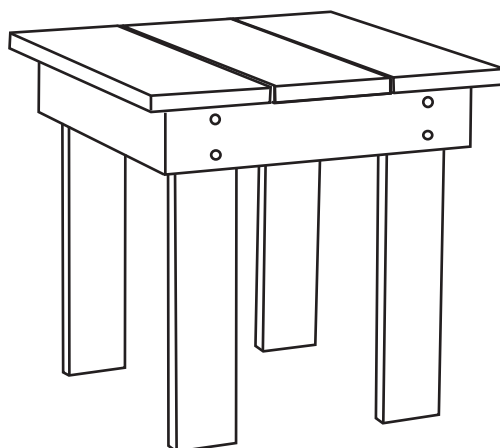

**Congratulations
on your assembly!**

Limited Warranty and Care Instructions

ONE (1) YEAR LIMITED WARRANTY (NON-TRANSFERABLE)

This product is covered under United General Supply's (UGS) one (1) year limited warranty. To the original purchaser of this piece of furniture, cooler, or accessory; UGS warrants that it will be free from defects in material and workmanship for up to one year from the date of purchase under normal use and proper care.

Replacement of defective or missing parts will be sent at no charge to the customer for a period of 30 days from the date of purchase. UGS will no longer be responsible for missing parts or hardware 30 days after date of purchase. Freight, packaging, labor, or material charges to and from our customer service center is not covered under the warranty and is therefore the customer's responsibility.

The limited warranty does not cover this piece of furniture, cooler or accessory for commercial purposes, abusive use, damage by modification, freeze damage, rust, fading and issues caused by improper care.

For minor defects or missing parts/hardware, please contact customer service immediately upon purchase. Please do not return product to the store unless the product is irreparable. A customer service agent may help determine whether the damage is repairable and will provide further instructions.

For returns and refunds, please refer to your local store return policy with proof of purchase. Proof of purchase (dated register receipt) will be required for warranty claims.

The use of power tools during assembly may void this warranty.

PROPER CARE INSTRUCTIONS

During long periods of non-use, store furniture in a covered and dry place.

Please register your product warranty at www.leighcountry.com/register.

Customer Service may be reached Monday through Friday from 9:00a.m. to 5:00p.m. CST.

HELP@UGSCO.COM OR 1-877-87LEIGH (53444)

Leigh  **Country**
Authentic Country® Living

DISTRIBUTED BY:
UNITED GENERAL SUPPLY CO., INC.
HOUSTON, TX 77036

www.LeighCountry.com